

名稱：前車架組合

圖號：S110M101

核准：

版次：0

日期：2010/01/20

母件品號: S11		S110M101: 1 of 2		currency:USD	print by: 2010/3/23
料號 - 圖號 - 品名	規格	- 英文品名及規格		-- 數量	-
Part NoDrawing NoDescription	Specification	- Description		-- Qty/Chair	
S110M101	車架組合	S11	S110M101		
31151053	S110A101 前車架焊接	電著 S11	-		1
31151083	S110A110 前防撞管焊接總成	電著 S11	-		1
51311201	SFM8*10C 螺絲	止付M8*10L鍍鋅(忠)	SET SCREW M8*10L		1
51411101	SFM8*15S 螺絲	套筒M8*15L黑(HP346*1) (貫)	INNER HEXAGON SCREW M8*15L BLACK		2
51804101	SPM3*06C 螺絲	P頭十字自攻 φ 1/8"*3/8"鋅 黑(S11)	-		4
51805101	SPM4*08D 螺絲	P頭十字M4*8L黑	PHILIP SCR W M4*8L BLACK		4
51806103	SPM4*10S 螺絲	P頭十字自攻去尾 φ 4*10L黑-			6
51807103	SPM5*15D 螺絲	P頭十字M5*15L黑	PHILIP SCREW BLACK		2
51807203	SPM5*12C 螺絲	P頭十字M5*12L鍍鋅全牙	PHILIP SCREW M5*12L		2
51809110	SPM6*10C 螺絲	P頭十字M6*10L黑	-		6
51809202	SPM6*15C 螺絲	P頭十字M6*15L鍍鋅全牙	SCREW FOR THE LEGEST PAD M6*15L		2
52104201	NTWU*06C 平螺帽	M6鍍鋅	FLAT NUT M6		6
52203201	NNM5*PCC 尼龍螺帽	M5(裝配課另行領取)(40M)	NYLON NUT M5		2
52204201	NNM6*P1C 尼龍螺帽	M6*P1.0(裝配課另行領取) (20M)	NYLON NUT M6		6
53103201	WE05102C 平華司	φ 5* φ 10*1t鍍鋅	FLAT WASHER Φ5*Φ10*1T		4
53104201	WE06133Z 平華司	φ 6* φ 13*1t鍍鋅	FLAT WASHER Φ6*Φ13 *1T		10
53302201	WS04095C 彈簧華司	M4鋅	SPRING WASHER M4		4

母件品號: S11		S110M101: 2 of 2		currency: USD	print by: 2010/3/23
項目 Item - Part No.	料號 Drawing No.	圖號 - 品名 Description	規格 Specification	- 英文品名及規格 - Description	-- 數量 - -- Qty/Chair
S110M101	車架組合		S11	S110M101	
71241380	S1100901	控制器固定板	鍍鋅 92.6*136*2t(S11*1金)	-	1
71251044	S1100168	拉柄	(S11*1仲)	-	1
71251045	R3300134	活動卡座	(S11*1)	-	1
71272330	S1100951	前車蓋	鮭魚紅(S11遮噴*1)	-	1
71272331	S1100952	背蓋	PP黑(S11*1智)	-	1
71272334	S1100954	左內襯板	PP黑 左 (S11*1智)	-	1
71272335	S1100955	右內襯板	PP 黑 右(S11*1智)	-	1
71281010	S1100961	腳踏底板	SPCC 372.1*203.7*2t(S11焊*1金)	-	1
72033006	PF600158	軸管防塵套黑	橡膠加長 型(PF6.S9.12.11*1吋)	RUBBER DUST COVER	1
78091045	R3300133	拉柄彈簧	φ 1.15*45mm(S11*1)	-	1

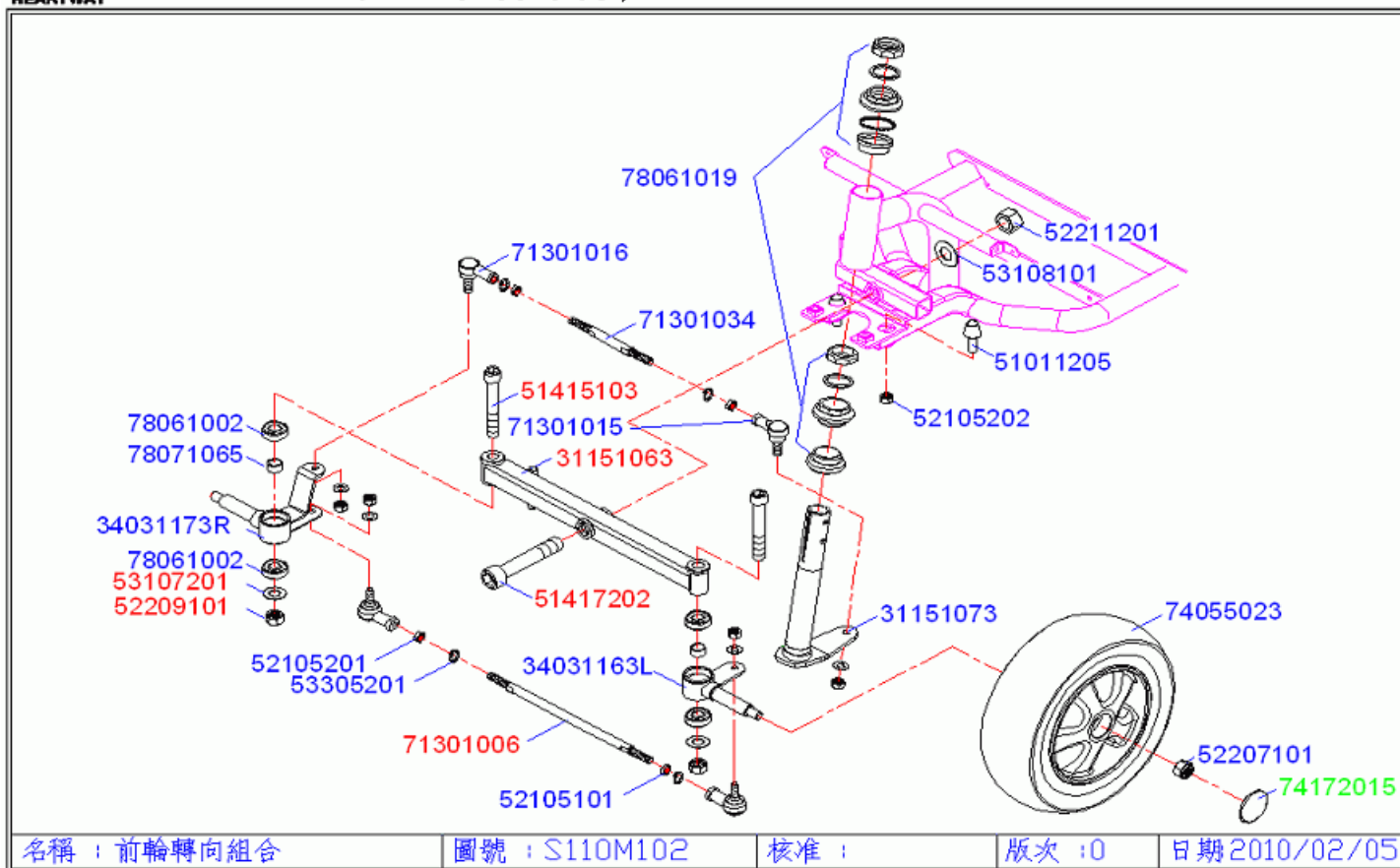

母件品號: S11		S110M102: 1 of 2		currency:USD	print by: 2010/3/23
料號 - 圖號 - 品名	規格	- 英文品名及規格		-- 數量	-
Part NoDrawing NoDescription	Specification	- Description		-- Qty/Chair	
S110M102	前輪轉向組合	S11	S110M102		
31151063	S110A102 前輪橫管焊接	電著 S11	-	1	
31151073	S110A105 轉向立軸焊接	電著 S11	-	1	
34031163	S110A103 前輪心軸焊接左	左 電著 S11	-	1	
34031173	S110A104 前輪心軸焊接右	右 電著 S11	-	1	
51011205	- 螺絲	避震橡膠螺絲M8*P1.25*20L(S11*2吋)	SHOCKPROOF RUBBER SCREW M8*P1.25*20L	2	
51415103	SFM1265D 螺絲	套筒M12*80L*P1.75黑全牙(DVL*1)	INNER HEXAGON SCREW M12*P1.75*80L BLACK	2	
51417202	SFM1690D 螺絲	套筒M16*90L鍍鋅半牙(S11*1)	-	1	
52105101	NTWU*08D 平螺帽	M8黑(忠)	FLAT NYLON NUT M8	2	
52105201	NTMJ*P8C 平螺帽	M8*P1.25左牙(PF2*2忠)	FLAT NUT M8*P1.25 (LH THREAD)	2	
52205202	NNM8*PDC 尼龍螺帽	M8鋅(裝配課另行領取)(8M)	NYLON NUT M8*P1.25	4	
52207101	NNM10P1D 尼龍螺帽	M10*P1.5黑(鑫)	NYLON NUT M10*P1.5	2	
52209101	NNM12PED 尼龍螺帽	M12*P1.75黑(鑫)	NYLON NUT M12*P1.75 BLACK	2	
52211201	NNM16PEC 尼龍螺帽	M16鍍鋅(P11.P11R*2)(貫)	NYLON NUT M16	1	
53105204	WE08182C 平華司	φ 8* φ 18*1.8t鍍鋅	FLAT WASHER Φ8*Φ18*1.8T	4	
53107201	WE12191C 平華司	φ 12* φ 19*1t鍍鋅	FLAT WASHER Φ12*Φ19*1T	2	
53108101	- 平華司	M16* φ 25*1.5t鋅黑	FLAT WASHER M16*Φ25*1.5T,BLACK	1	

母件品號: S11		S110M102: 2 of 2		currency: USD	print by: 2010/3/23
項目 Item. - Part No.	料號 Drawing No.	圖號 - 品名 Description	規格 Specification	- 英文品名及規格 - Description	-- 數量 - -- Qty/Chair
S110M102	前輪轉向組合		S11	S110M102	
53116202	H1E01080	平華司	φ 1/2*φ 19*2t鍍 鋅(PF1S.PF36*4)	FLAT WASHER Φ 1/2*Φ 19*2T	4
53305201	WS08095D	彈簧華司	M8鍍鋅	SPRING WASHER(M6)	4
71241062	PF301360	轉向軸墊套環	φ 16*1.4t*20mm 鋅(PF156S11*2)(兵)	SPACER Φ 16*1.4T*20L	2
71301006	PF10321Z	轉向推桿連接螺絲	M8*265L鍍鋅(PF1S9*1貞)	COUPLING BOLT M8X265L	1
71301015	PF10241Z	萬向接頭	長L左 牙RBL8(PF12356S12S34*2宏)	TURNING COUPLING,LH	2
71301016	PF10242Z	萬向接頭	短右(PF12356S12*2宏)	TURNING COUPLING,RH	2
71301034	PF200144	轉向推桿連接螺絲	M8*95L鍍 鋅(PF2S.S9.S34.S11*1)(貞)	COUPLING BOLT M8X95L	1
74055023	S1100611	PU萬向輪	全PU含輪轂 240*75 黑(S11大*2鈺)	-	2
74172015	H900501S	托架管塞	黑 H9.MR.HP6(P11.HPS*2)	TUBE END PLUG	2
78061002	BR6001SZ	軸承	6001鐵蓋 (H9N3HP5.H12*4) (法)	BEARING (Φ 12*28*8B) 6001	4
78061019	H0HD5070	八件式軸承組	TH-1150W輪椅用(業務下單 用94018001)	STEERING STEM BEARING TH-1150W BLACK	1
78071062	S1200606	前左輪轂間隔環	φ 19*1.6t*7.9L鍍 鋅(S12*1煜)	FRONT HUB SPACER L	2
78071065	S1100125	轉向墊套管	φ 16*1.4t*10.2L鍍 鋅(S11*2億)	-	2

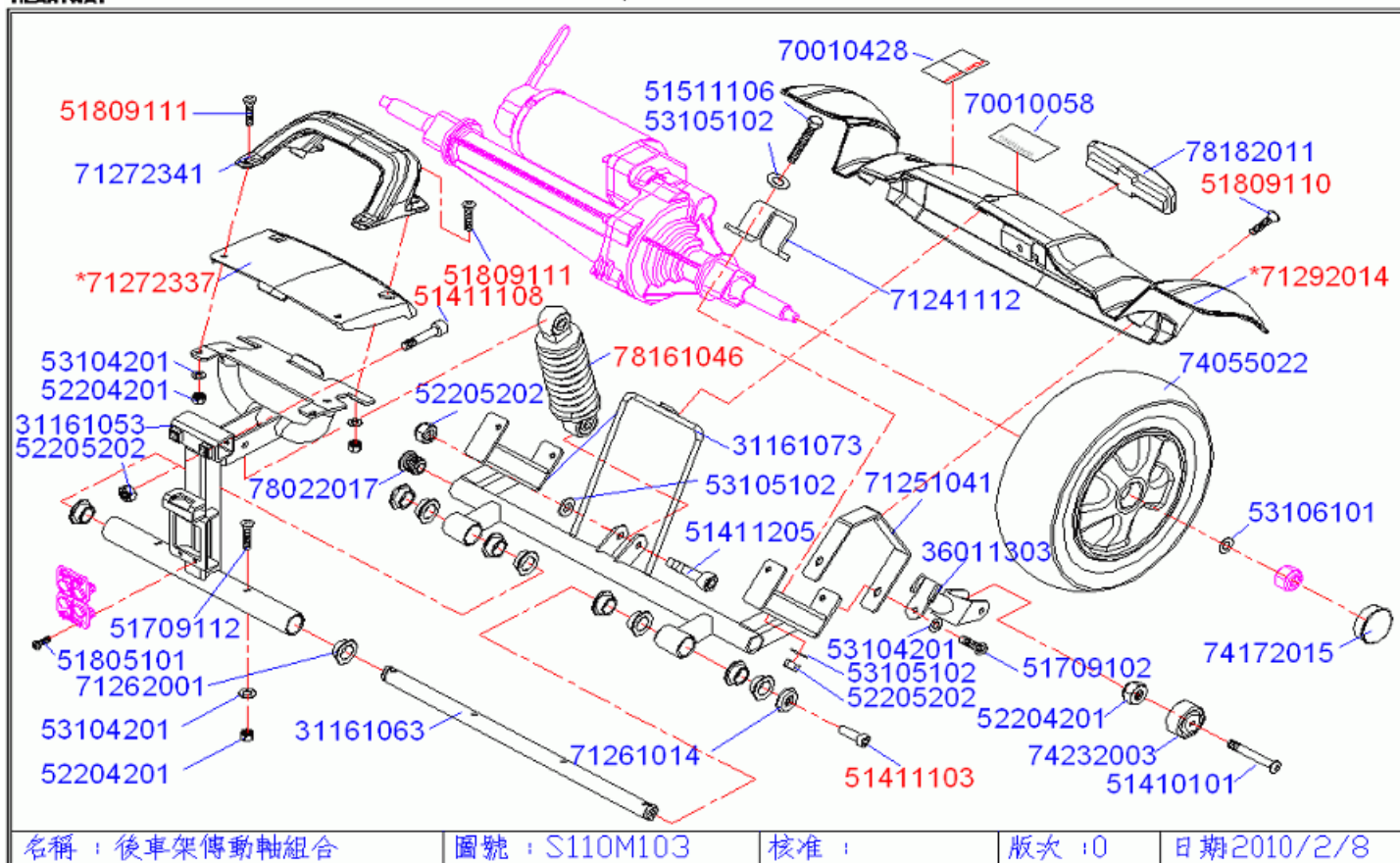

母件品號: S11		S110M103: 1 of 2		currency:USD	print by: 2010/3/23
料號 - 圖號 - 品名	規格	- 英文品名及規格		-- 數量	-
Part NoDrawing NoDescription	Specification	- Description		-- Qty/Chair	
S110M103	後車架傳動軸組合	S11	S110M103		
31161053	S110A106 中車架焊接	電著 S11	-		1
31161063	S110A108 轉動內套管焊接	電著 S11	-		1
31161073	S110A109 後車架焊接	電著 S11	-		1
36011303	S110A112 防後傾管焊接	電著 S11	-		2
51410101	SLM6*38D 螺絲	大扁頭M6*38L黑(PF2*2)	INNER HEXAGON BOLT M6*38L BLACK		2
51411103	SFM8*25S 螺絲	套筒M8*25L黑全牙(貫)	HEX SOCKET HEAD BOLT M8*25L, BLACK		2
51411108	SFM8*50D 螺絲	套筒M8*50L黑半牙(P11R*8貫)	HEX SOCKET HEAD BOLT M8*50L BLACK		2
51411205	SFM8*40C 螺絲	套筒M8*40L鍍鋅全牙(忠)	INNER HEXAGON SCREW M8*40L		2
51511106	SHM8*40D 螺絲	六角頭M8*40L黑全牙	HEXAGON BOLT M8*40L BLACK		4
51709102	SLM6*15D 螺絲	半圓內六M6*15L黑全牙(PF7*4忠)	INNER HEXAGON BOLT M6*15L BLACK		4
51709112	SLM6*35Z 螺絲	半圓內六M6*35L黑全牙	PHILIP SCREW M6*35L BLACK		2
51805101	SPM4*08D 螺絲	P頭十字M4*8L黑	PHILIP SCR W M4*8L BLACK		4
51809110	SPM6*10C 螺絲	P頭十字M6*10L黑	-		3
51809111	SPM6*15C 螺絲	P頭十字M6*15L黑	-		4
52204201	NNM6*P1C 尼龍螺帽	M6*P1.0(裝配課另行領取)	NYLON NUT M6 (20M)		8
52205202	NNM8*PDC 尼龍螺帽	M8鋅(裝配課另行領取)(8M)	NYLON NUT M8*P1.25		8

母件品號: S11		S11M103: 2 of 2		currency: USD	print by: 2010/3/23	
項目 Item.	料號 Part No.	圖號 Drawing No.	品名 Description	規格 Specification	- 英文品名及規格 - Description	-- 數量 -- Qty/Chair
S11M103		後車架傳動軸組合		S11	S11M103	
53104201	WE06133Z	平華司	φ 6* φ 13*1t鍍鋅		FLAT WASHER Φ6*Φ13 *1T	10
53105102	WE08164D	平華司	φ 8* φ 16*1t黑		FLAT WASHER Φ8*Φ16*1T BLACK	10
53106101	WE10202D	平華司	φ 10* φ 20*1.8t黑		FLAT WASHER Φ10*Φ20*1.8T	2
70010058	P5308030	車蓋貼紙	WARNING長方(馬達釋放)		MOTOR RELEASE WARNING STICKER	1
70010428	S1200986	釋放指示貼紙	橢圓白底 直式25mm*60mm - S12			1
71241112	P3303050	傳動軸夾板	U型新恆單馬達(PSR33*2)電 著黑		CLAMP FOR P53/P33/S33 TRANSAXLE	2
71251041	S1100164	側鎖固板	電著113*92.4*3t SPCC(S11*2)	-		2
71261014	S1100137	鎖緊墊套	S15C 5t電著(S11*2億)	-		2
71262001	S1100138	轉動襯套	NYLON6 本 色 φ 28*10(S11*10)	-		10
71272337	S1100956	提把座板	鮭魚紅(S11*1)	-		1
71272341	S1100959	提把	PP黑(S11.S34*1元)	-		1
71292014	S1100960	後保桿	鮭魚紅(S11*1)	-		1
74055022	S1100610	PU驅動輪	全PU含輪轂 240*75黑(S11大*2鈺)	-		2
74172015	H900501S	托架管塞	黑 H9.MR.HP6(P11.HPS*2)		TUBE END PLUG	2
74232003	H900903S	防傾輪	(H9.HP1HD.MR23.P12.P21*4 良)		ANTI-TIPPING WHEEL	2
78022017	H900116S	圓管塞	φ 1"黑(HP5.MR3*2)(睦)		TUBE END PLUG Φ1"	2
78161046	S1100904	避震彈簧	黃,HY-****(150L K7.09) (S11*1)	-		1
78182011	-	反光片	#TF-508B(鎖螺 絲)紅(S12.S11*1)		REAR REFLECTOR	1

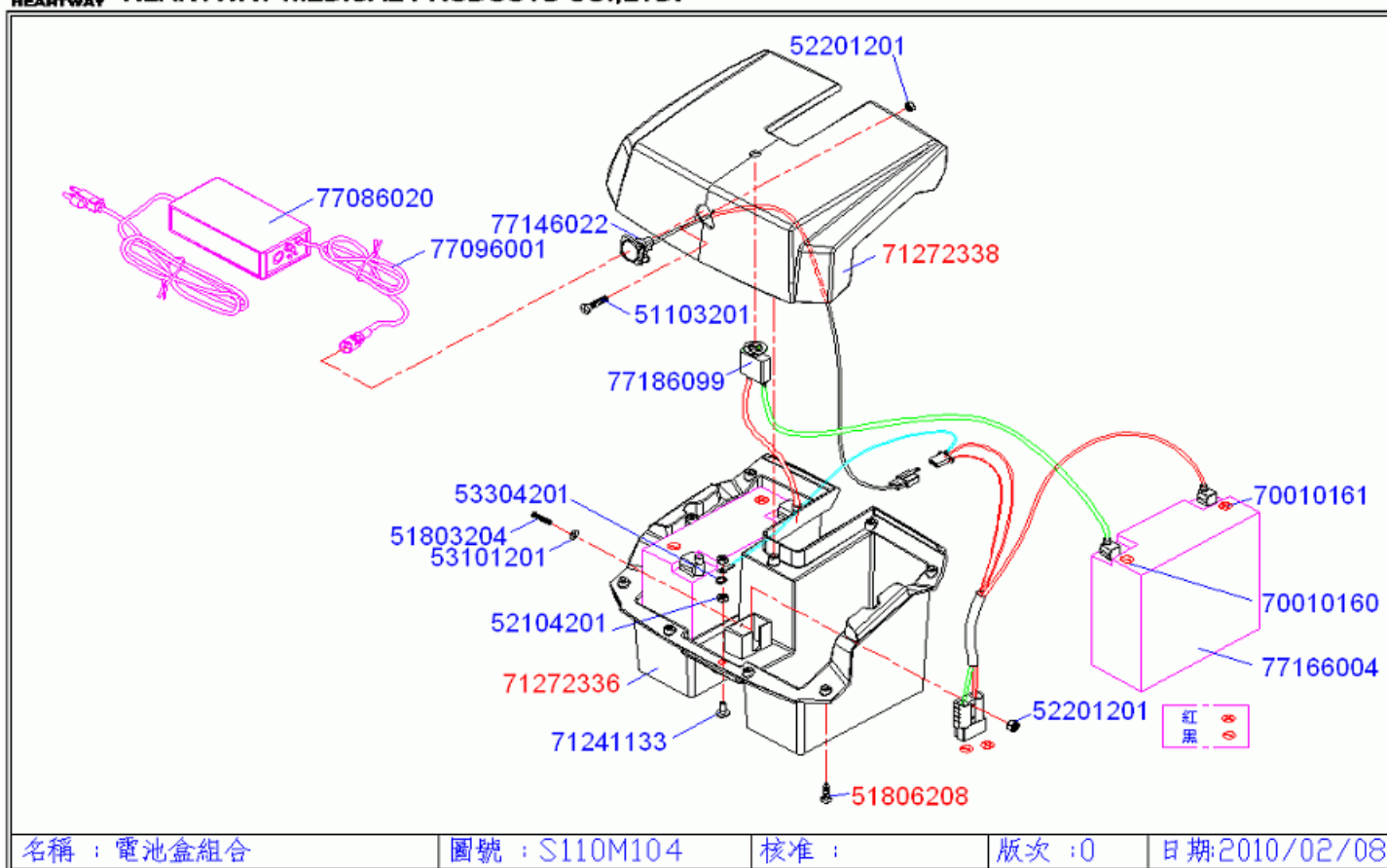

母件品號: S11		S110M104: 1 of 2		currency:USD	print by: 2010/3/23
料號 - 圖號 - 品名	規格	- 英文品名及規格		-- 數量	-
Part NoDrawing NoDescription	Specification	- Description		-- Qty/Chair	
S110M104	電池盒組合	S11	S110M104		
51103201	SDM3*10C 螺絲	皿頭十字M3*10L鍍鋅全牙(PTF27*2忠)	PHILIP SELF TAPPING SCREW M3*10L	2	
51709111	SLM6*35D 螺絲	半圓內六M6*35L黑半牙	INNER HEXAGON BOLT M6*35L BLACK	1	
51709119	SLM6*50D 螺絲	半圓內六M6*50L黑半牙15長	ALLEN SCREW M6X50L FULL THREAD	1	
51803204	- 螺絲	P頭十字M3*25L	PHILIP SCREW M3*25L	2	
51806208	- 螺絲	P頭十字自攻去尾φ4*14L鍍鋅	PHILIP SELF TAPPING SCREW(Φ4*14L)	9	
52104201	NTWU*06C 平螺帽	M6鍍鋅	FLAT NUT M6	2	
52201201	NNM3*PAZ 尼龍螺帽	M3	NYLON NUT M3	2	
52201201	NNM3*PAZ 尼龍螺帽	M3	NYLON NUT M3	2	
52204101	NNM6*P1D 尼龍螺帽	M6全黑	DOME NYLON NUT M6 BLACK	2	
53101201	WE03101Z 平華司	M3*φ8*1t鍍鋅	FLAT WASHER M3*8*1T	2	
53104201	WE06133Z 平華司	φ6*φ13*1t鍍鋅	FLAT WASHER Φ6*Φ13*1T	1	
53304101	WS00095S 彈簧華司	M6黑	SPRING WASHER M6 BLACK	2	
53304201	WS00095D 彈簧華司	M6鍍鋅	SPRING WASHER M6	1	
70010160	HP10914A 貼紙	正字線路貼紙(紅)	LABEL (RED)(+)	2	
70010161	HP10915S 貼紙	負字線路貼紙(黑)	LABEL (BLACK)(-)	2	
70109014	HP409230 公黏扣帶50mm	背膠裁5cm(裝配課另行領取)	VELCRO (HOOK)	2	

母件品號: S11		S110M104: 2 of 2		currency: USD	print by: 2010/3/23	
項目 Item.	料號 Part No.	圖號 Drawing No.	品名 Description	規格 Specification	- 英文品名及規格 - Description	-- 數量 -- Qty/Chair
S110M104		電池盒組合		S11	S110M104	
70109018	HP409240	母黏扣帶50mm	背膠裁7cm(裝配課另行領取)	VELCRO (LOOP)		2
71241133	S330E101	銅接頭(固定)	§ 15*18mm(S33*1.S34.S11*5 CONTACT(FIXING) 億)			1
71272336	S1100956	電池下蓋=S1100956	ABS黑色(S11*1智)	-		1
71272338	S1100957	電池上蓋=S1100957	ABS黑色(S11*1智)	-		1
77086020	-	充電器本體(S33.S34)	4C24020-24V-2A-OFF(S33.K T1)	CHARGER (4C24020-24V-2A-OFF)		1
77096001	HP1E9150	充電器電源線	美規插頭 AL-201	POWER CABLE FOR CHARGER		1
77146022	P530952E	充電插座線組	P53	CHARGING SOCKET BLACK CIRCUIT COMBINATION		1
77166004	WP22-12E	電池	12V/22Ah(P33.P53.S11*2)(GS BATTERY PXC12180)			2
77186098	-	電池接線組(二)(電池盒)	S-drive S11	-		1
77186099	-	電池接線組(三)(斷)	S-drive S11	-		1

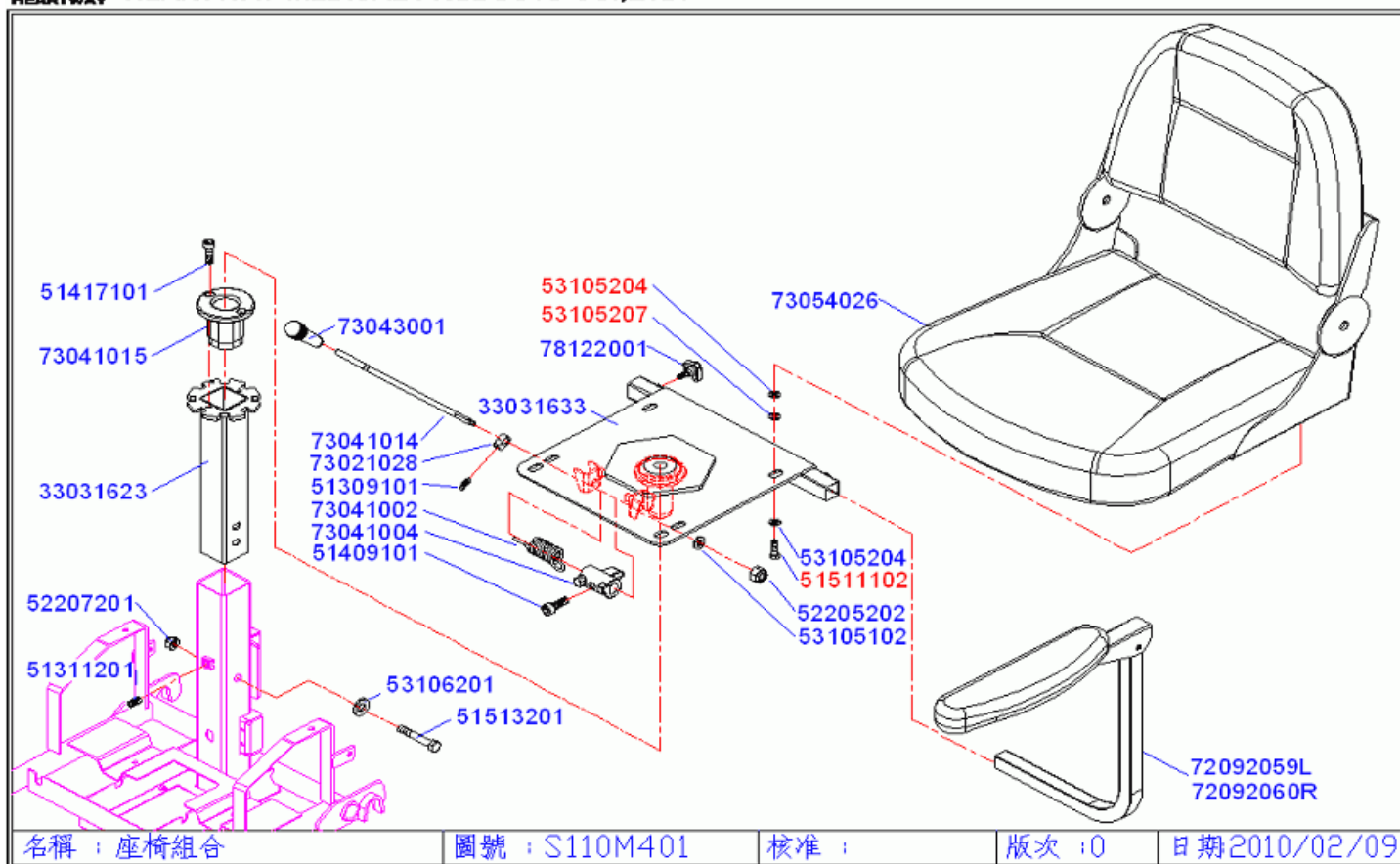

母件品號: S11		S110M401: 1 of 2		currency:USD	print by: 2010/3/23
料號 - 圖號 - 品名	規格	- 英文品名及規格		-- 數量 --	-
Part NoDrawing NoDescription	Specification	- Description		-- Qty/Chair	
S110M401	座椅組合	S11	S110M401		
33031623	S110A401	座椅內套管焊接	電著 S11	-	1
33031633	S110A402	座椅基板焊接總成	電著 S11	-	1
51309101	SFM6*08C	螺絲	止付M6*8L尖尾 黑(OT 14"輪.S12*1貫)	SET SCREW M6X8L	1
51311201	SFM8*10C	螺絲	止付M8*10L鍍鋅(忠)	SET SCREW M8*10L	1
51409101	SFM6*12D	螺絲	套筒M6*12L黑(PF2*1PTF7*2 忠)	INNER HEXAGON SCREW M6*12L BLACK	1
51417101	-	螺絲	套筒M16*70L(P4A,P13*1) (貫)	INNER HEXAGON SCREW M16*70L	2
51511102	SHM8*20D	螺絲	六角頭M8*20L黑(HP3*6) (鑫)	HEXAGON BOLT M8*20L BLACK	4
51513201	SHM1050C	螺絲	六角頭M10*50L鍍鋅半牙	HEXAGON BOLT M10*50L	1
52205202	NNM8*PDC	尼龍螺帽	M8鋅(裝配課另行領取)(8M)	NYLON NUT M8*P1.25	4
52207201	NNM10P1C	尼龍螺帽	M10*P1.5鋅(40H)	NYLON NUT (M10*P1.5)	1
53105102	WE08164D	平華司	φ 8* φ 16*1t黑	FLAT WASHER Φ8*Φ16*1T BLACK	4
53105204	WE08182C	平華司	φ 8* φ 18*1.8t鍍鋅	FLAT WASHER Φ8*Φ18*1.8T	8
53105207	WE08182C	平華司	φ 8.2* φ 18*3t鍍鋅	-	4
53106201	WE101610	平華司	φ 10.2* φ 16*1t鍍鋅	FLAT WASHER Φ10.2*Φ16*1T	2
72092059	-	左扶手組	含PU面.管件 (S11.S34.PTF3*1(美)	-	1

母件品號: S11		S110M401: 2 of 2		currency: USD	print by: 2010/3/23	
項目 Item.	料號 Part No.	圖號 Drawing No.	品名 Description	規格 Specification	- 英文品名及規格 - Description	-- 數量 -- Qty/Chair
S110M401		座椅組合		S11	S110M401	
72092060	-		右扶手組	含PU面.管件 (S11.S34.PTF3*1(美)	-	1
73021028	HP400435		固定桿鎖塊	#P4583裁8mm電 著T6(HP4*1伸)	-	1
73041002	HP404010		座椅彈簧	HP4 鍍鋅	RELEASE LEVER SPRING	1
73041004	HP404030		座椅定位塊	HP34 PF12(鉗孔電著完成)	SWIVEL SEAT LOCKING BLOCK	1
73041014	HP40415S		迴轉固定桿	283.3mm(HP3.P4F.TC1.S34.S 11*1伸)	RELEASE LEVER	1
73041015	HP404230		座椅轉軸套筒	鐵(含鑽孔攻牙鍍鋅) (HP34PF12S11)	SEAT POST SLEEVE (STAINLESS STEEL)	1
73043001	PF10420S		座椅迴桿手握 黑	110mm(HP34 PF1.TC1S11S34)	GRIP FOR RELEASE LEVER	1
73054026	-		座椅(S11)	SB941 無頭枕無後傾 MC7/MC22車雙紅 線(S11鑫*1)	-	1
78122001	PDS0125S		蝶形把手	M8*15L黑 #203G(6024*6P4ADP3D.S34. S11*2森)	PLASTIC HEAD BOLT	2

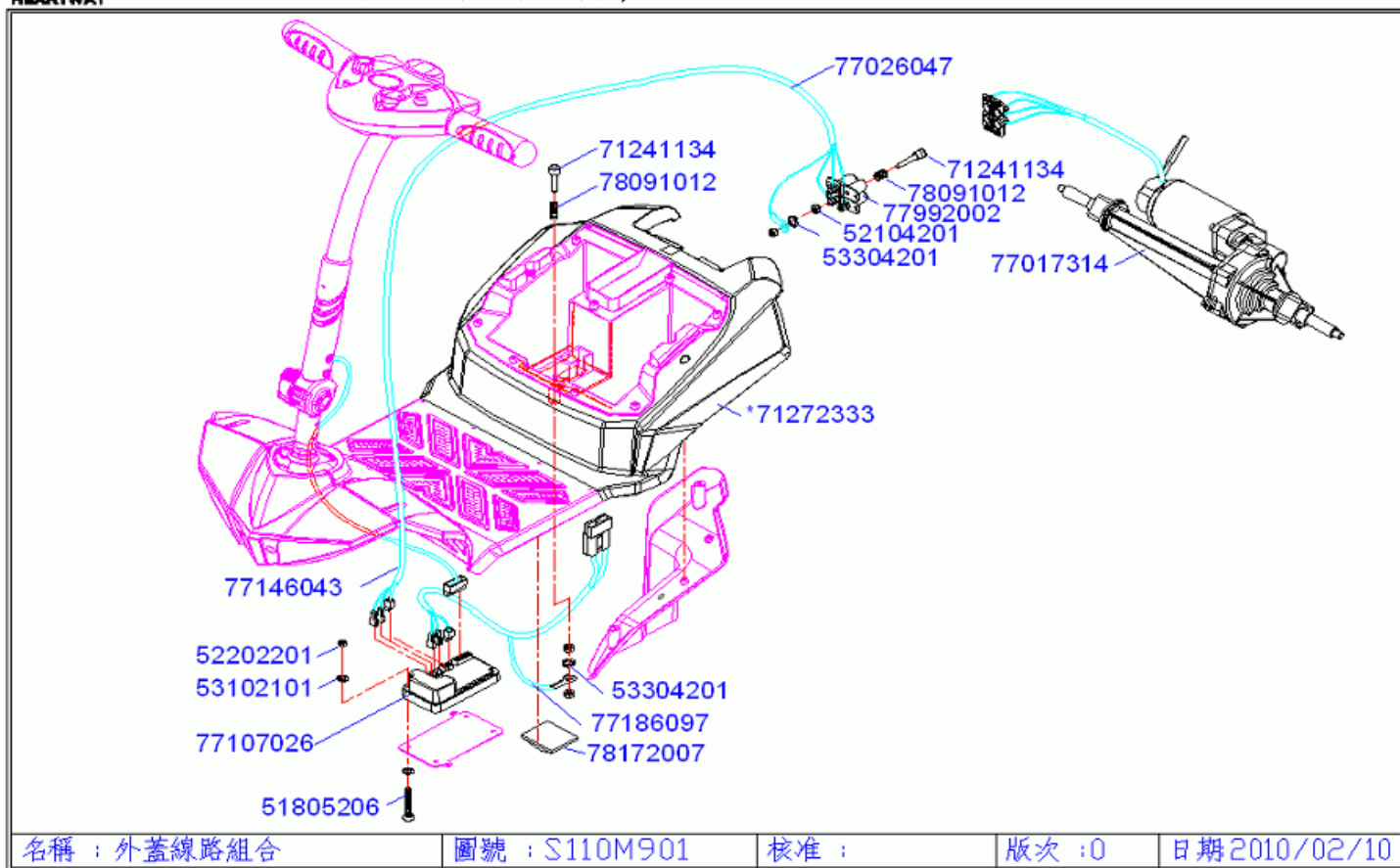

母件品號: S11		S110M901: 1 of 2		currency:USD	print by: 2010/3/23
料號 - 圖號 - 品名	規格	- 英文品名及規格		-- 數量	-
Part NoDrawing NoDescription	Specification	- Description		-- Qty/Chair	
S110M901	外蓋線路組合	S11	S110M901		
51805206	SPM4*30C 螺絲	P頭十字M4*30L鍍鋅	PHILIP SCREW M4*30L	2	
51806202	SPM4*20C 螺絲	小P頭十字自攻φ4*20鋅	PHILIP SELF TAPPING SCREW(Φ4*20L)	2	
51808101	STM5*15D 螺絲	P頭十字自攻φ5*15L黑	PHILIP SELF TAPPING SCREW Φ5*15L	8	
52104201	NTWU*06C 平螺帽	M6鍍鋅	FLAT NUT M6	18	
52202201	NNM4*P1C 尼龍螺帽	M4	NYLON NUT M4	2	
53102101	WE04080D 平華司	φ4*φ8*1t黑	FLAT WASHER Φ4*Φ8*1T BLACK	4	
53103201	WE05102C 平華司	φ5*φ10*1t鍍鋅	FLAT WASHER Φ5*Φ10*1T	2	
53304201	WS00095D 彈簧華司	M6鍍鋅	SPRING WASHER M6	9	
71241133	S330E101 銅接頭(固定)	§ 15*18mm(S33*1.S34.S11*5 CONTACT(FIXING)億)		4	
71241134	S330E102 銅接頭(活動)	§ 14*52mm(S33*1.S34.S11*5 CONTACT(ACTIVITY)億)		5	
71272333	S1100953 後蓋	鮭魚紅 S11	-	1	
71272334	S1100954 左內襯板	PP黑 左(S11*1智)	-	1	
71272335	S1100955 右內襯板	PP 黑 右(S11*1智)	-	1	
77017314	- S11馬達減速機	A9Y7X05670 (士電S11)	-	1	
77026047	- 馬達接線組	S11 (S-DRIVE)	-	1	
77107026	PF6A8010 控制器	P&G S-Drive 70A(S33.S11.R33.PF3.TC1)	CONTRLLER(P&G S.DRIVE 70A)	1	

母件品號: S11		S110M901: 2 of 2		currency: USD	print by: 2010/3/23	
項目 Item.	料號 Part No.	圖號 Drawing No.	品名 Description	規格 Specification	- 英文品名及規格 - Description	-- 數量 -- Qty/Chair
S110M901		外蓋線路組合		S11	S110M901	

77146043	P530953E		上控制線組(含把手)鮭魚紅 S11		-	1
77186097	-		電池接線組(一)(控) S-drive S11		-	1
77992001	S3400911		電氣前基座	20*60*30 咬花 尼龍黑(S34.S11*2尙)	-	2
77992002	S3400910		電氣後基座	40*30*11 咬花 尼龍黑(S34.S11*2尙)	-	2
78091012	H000104Z		彈簧	φ 0.9*10D*6N*30L	SPRING (Φ0.9*10D*6N*25L)	5
78172007	-		配線固定鈕	粘式配線固定座HC102BK黑(HW1*4)	SADDLE SHAPE WIRE CLIP	2

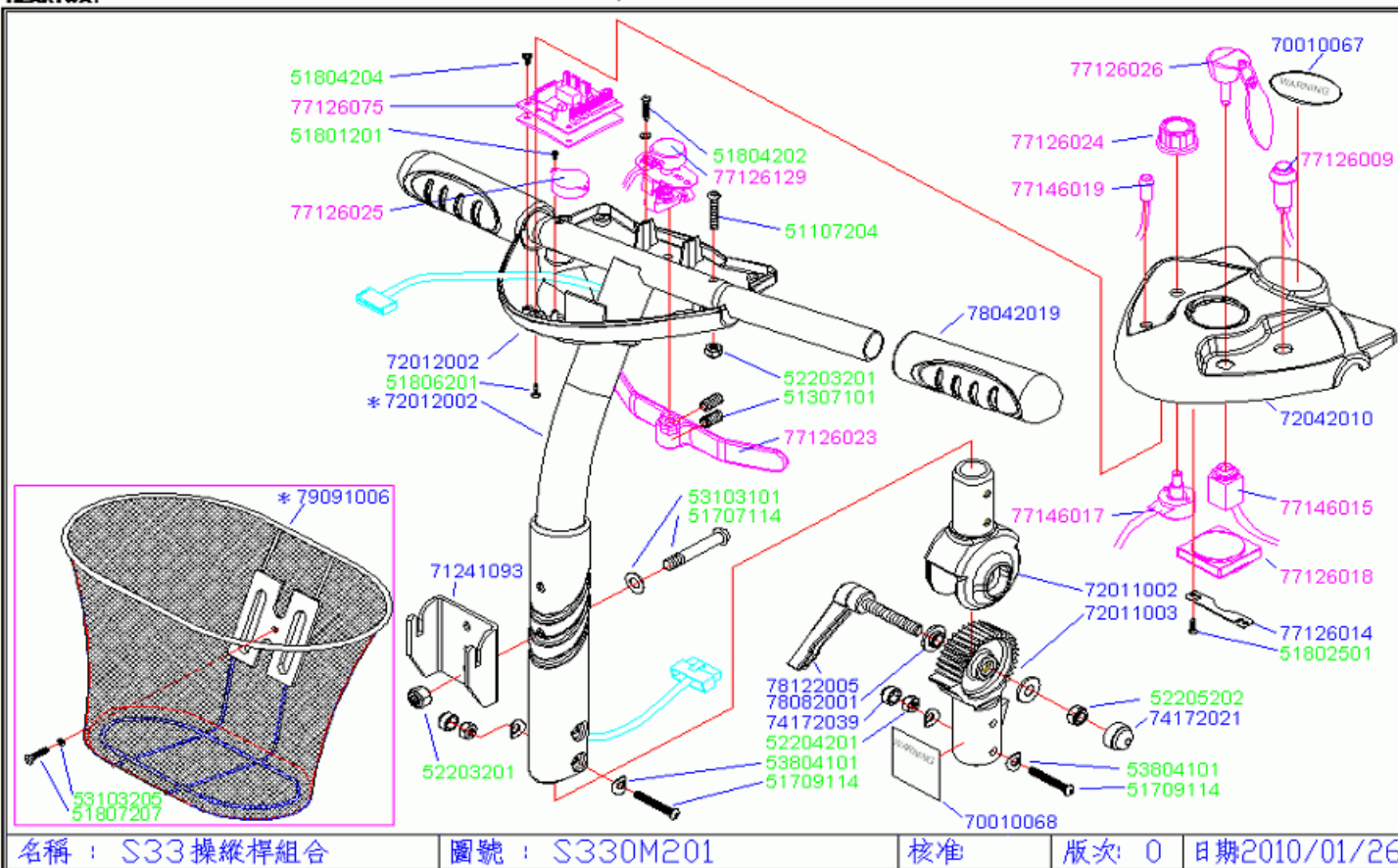

名稱：S33 操縱桿組合

圖號：S330M201

核准

版次：0

日期2010/01/26

母件品號: S11	S330M201: 1 of 2	currency:USD	print by: 2010/3/23
料號 - 圖號 - 品名 Part NoDrawing NoDescription	規格 Specification	- 英文品名及規格 - Description	-- 數量 - -- Qty/Chair
S330M201	操縱桿組合	S33	S33\S330M201

51107204	SDM5*33Z	螺絲	皿頭十字M5*33L鍍鋅	PHILIP SCREW M5*33L	2
51307101	SFM5*08S	螺絲	止付M5*8L黑	SET SCREW M5X8L BLACK	2
51707114	SLM5*45D	螺絲	半圓內六M5*45L黑半牙	INNER HEXAGON BOLT(M8*45L)	2
51709114	SLM6*40D	螺絲	半圓內六M6*40L黑全牙	INNER HEXAGON SCREW M6*40L	4
51801201	SPM2*04C	螺絲	P頭十字自攻φ2*4L鍍鎳	PHILIP SCREW M2.6*4L	2
51802501	-	螺絲	P頭十字自攻φ2.6*6L五彩	PHILIP SELF TAPPING SCREW Φ2.6*6L	2
51804202	SPM35*15C	螺絲	P頭十字自攻φ3.5*15L	PHILIP SELF TAPPING SCREW M3.5*15L	2
51804204	-	螺絲	P頭十字自攻去尾φ3*10L五彩	PHILIP SELF TAPPING SCREW Φ3*10L	2
51806201	SPM4*10C	螺絲	P頭十字自攻φ4*10L鍍鋅	PHILIP SELF TAPPING SCREW Φ4*10L	3
51807207	SPM5*25C	螺絲	P頭十字M5*25L鍍鋅	PHILIP SCREW M5*25	1
52203201	NNM5*PCC	尼龍螺帽	M5(裝配課另行領取)(40M)	NYLON NUT M5	4
52204201	NNM6*P1C	尼龍螺帽	M6*P1.0(裝配課另行領取)(20M)	NYLON NUT M6	4
52205202	NNM8*PDC	尼龍螺帽	M8鍍(裝配課另行領取)(8M)	NYLON NUT M8*P1.25	1
53103101	WE05102D	平華司	φ5*φ10*1t黑	FLAT WASHER Φ5*Φ10*1T	4
53103205	-	平華司	φ5*φ14*1t鍍鋅	FLAT WASHER Φ5*Φ14*1T	1
53804101	WU06197D	弧形華司	M6黑	CURVE WASHER M6 (BLACK)	8

母件品號: S11		S330M201: 2 of 2		currency: USD	print by: 2010/3/23	
項目 Item.	料號 Part No.	圖號 Drawing No.	品名 Description	規格 Specification	- 英文品名及規格 - Description	-- 數量 -- Qty/Chair
S330M201		操縱桿組合		S33	S33\S330M201	
70010067	P5308010	貼紙	WARNING橢圓橘底 P53	STICKER (WARNING)		1
70010068	P5308020	貼紙	WARNING正方Make sure P53	STICKER (WARNING)		1
71241093	W1301250	菜籃架(3孔)	電著(PF12356.W13P33PT3S33R33S34*1金)	BASKET BRACKET		1
72011002	P530201S	上折合座	電著黑 P53.PT3.PF123	STEERING FOLDING MECHANISM (UPPER)		1
72011003	P530202S	下折合座	電著 P53.PT3.PF123	STEERING FOLDING MECHANISM (LOWER)		1
72042010	P5301570	把手上蓋	黑(P53.S33.R33.TC1.S34.S11*1昱)	HANDLE TOP COVER		1
74172021	P530205S	M8尼帽防塵蓋	M8 黑 PP(裝配課另行領取)	NYLON NET CAP(M8)		1
74172039	HP600133	M6尼帽防塵蓋	M6 黑 PP(裝配課另行領取)	NYLON NET CAP(M6)		4
77126009	P330967E	喇叭開關線組	P33PF4(絲)(無段)	HORN BUTTON WITH WIRING		1
77126014	P530906C	電表固定板	(P53.S33.TC1.S34.S11*1泉)(含電鏢)	POWER METER BACKET		1
77126018	P530947E	電表線組	(P53.R33.S33*1託)映興	POWER METER CIRCUIT COMBINATION		1
77126023	P53A202S	速控撥板	P53 黑(需印刷)(S33.TC1.S34.S11*1)	WELDED WIGWAG ASSY		1
77126024	P53A8250	調速旋鈕蓋	#15-1184銀頭(大)(TC1.S33.S34.S11鈦*1)	SPEED ADJUSTING KNOB		1
77126025	P53A902S	蜂鳴器	P5320C6(S33.S34.TC1.S11*1)	BUZZER		1
77126026	P53A905S	電源鑰匙(1份2支)	(供插頭)鑰匙圈總成(託2插頭1鐵)	IGNITION KEY FOR PF5/PF6		1
77126075	-	上控基板總成	S-drive(S33.S34.S11.R33.TC1*1凱)	(S-DRIVE)70A PF12 P&G		1
77126129	-	電位計總成(含線組)	S33.P53.R33.S34.S11.TC1(黑 - 免調30mm.25N)			1
77146015	P330949E	KEY座線組	(P33PF3PT3)(映託77126033)	IGNITION KEY SOCKET WIRING		1
77146017	P330951E	調速電阻線組	P33PF3PT3PF4	SPEED POTENTIOMETER WIRING		1
77146019	P330960E	指示燈線組	P33PF3PT3(映託77126040)	STATUS PILOT WIRING		1
78042019	P530207S	手握	TPR黑(R33.TC1.S34*2昱)	HANDLE GRIP		2
78082001	PF10607S	扶手肩形墊圈	塑膠黑(HP6*6.P4F*8.S11*2睦)	SHOULDER SHAPE WASHER(20*5)		2
78122005	M8-65*40	機械把手	M8*40L黑#65(PF3.S33R33.TC1.S34.S11*1森)	QUICK RELEASE HANDLE(M8*40L)		1