



SPARE PARTS MANUAL

Knightsbridge-S

Knightsbridge-S

FR168-3S



INDEX

P1 HANDLE BAR ASSEMBLY

P2 CHASSIS MOULDINGS

P3 STEERING

P4 FRONT CHASSIS ASSEMBLY

P5 REAR CHASSIS ASSEMBLY-DRIVE SYSTEM

P6 SEAT ASSEMBLY

P7 CONSOLE AND WIRING SYSTEM

HANDLE BAR ASSEMBLY

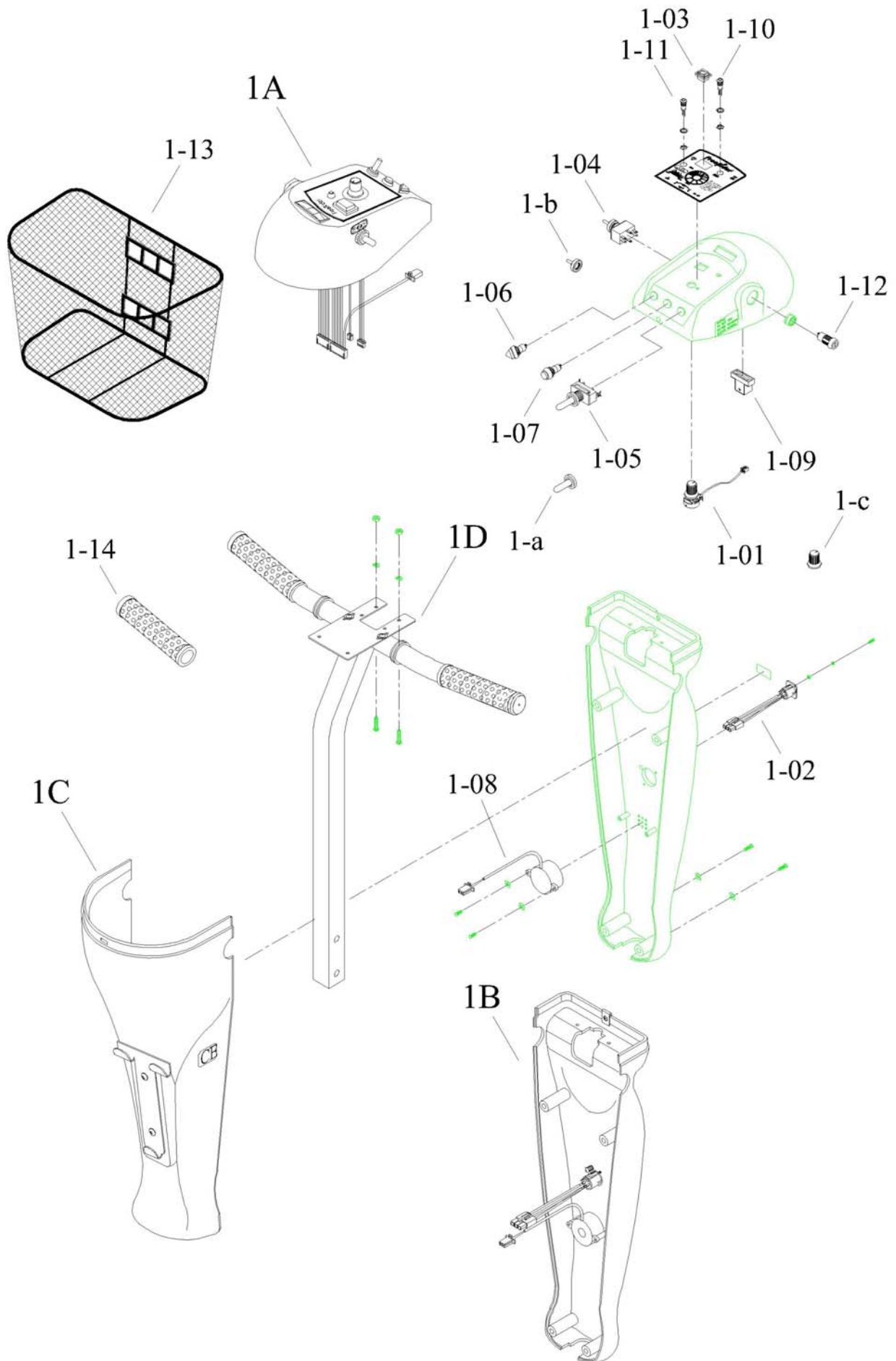

HANDLE BAR ASSEMBLY

DRAWING NO.	PART NO.	PART NAME	€	GBP	USD
1A	AA01-0200-R1	TOP CONSOLE COVER ASSY.			
1B	AA02-0100-R1	HANDLE BAR COVER REAR ASSY.			
1C	AA03-0400-R1	HANDLE BAR COVER FRONT ASSY.			
1D	PA01-A300	HANDLE BAR ASSY.			
1-01	PAE1-0100-MO	VARIABLE RESISTOR 20KVR ASSY. (HI/LO)			
1-02	PAE1-0405-NP	CHARGER SOCKET ASSY.			
1-03	PAE1-0800	HEADLIGHT SWITCH ASSY.			
1-04	PKE1-0104	HI/LO SPEED SWITCH ASSY			
1-05	PKE1-0105	INDICATOR SWITCH ASSY.			
1-06	PKE1-0101	WARNING LIGHT SWITCH			
1-07	PKE1-0103	HORN BUTTON			
1-08	PKE1-0603	HORN			
1-09	PKE1-0700	BATTERY METER ASSY.			
1-10	PKE1-0800	INDICATOR LED (GREEN)			
1-11	PKE1-0802	HI/LO SPEED LED (RED)			
1-12	PM01-0100	KEY SWITCH			
1-13	PM90-0100	BASKET			
1-14	PP02-0501	HAND GRIP			
1-a	PP01-0200	INDICATOR SWITCH CAP			
1-b	PP01-0201	HI/LO SPEED SWITCH CAP			
1-c	PP01-0500	SPEED KNOB			

CHASSIS MOUNTINGS

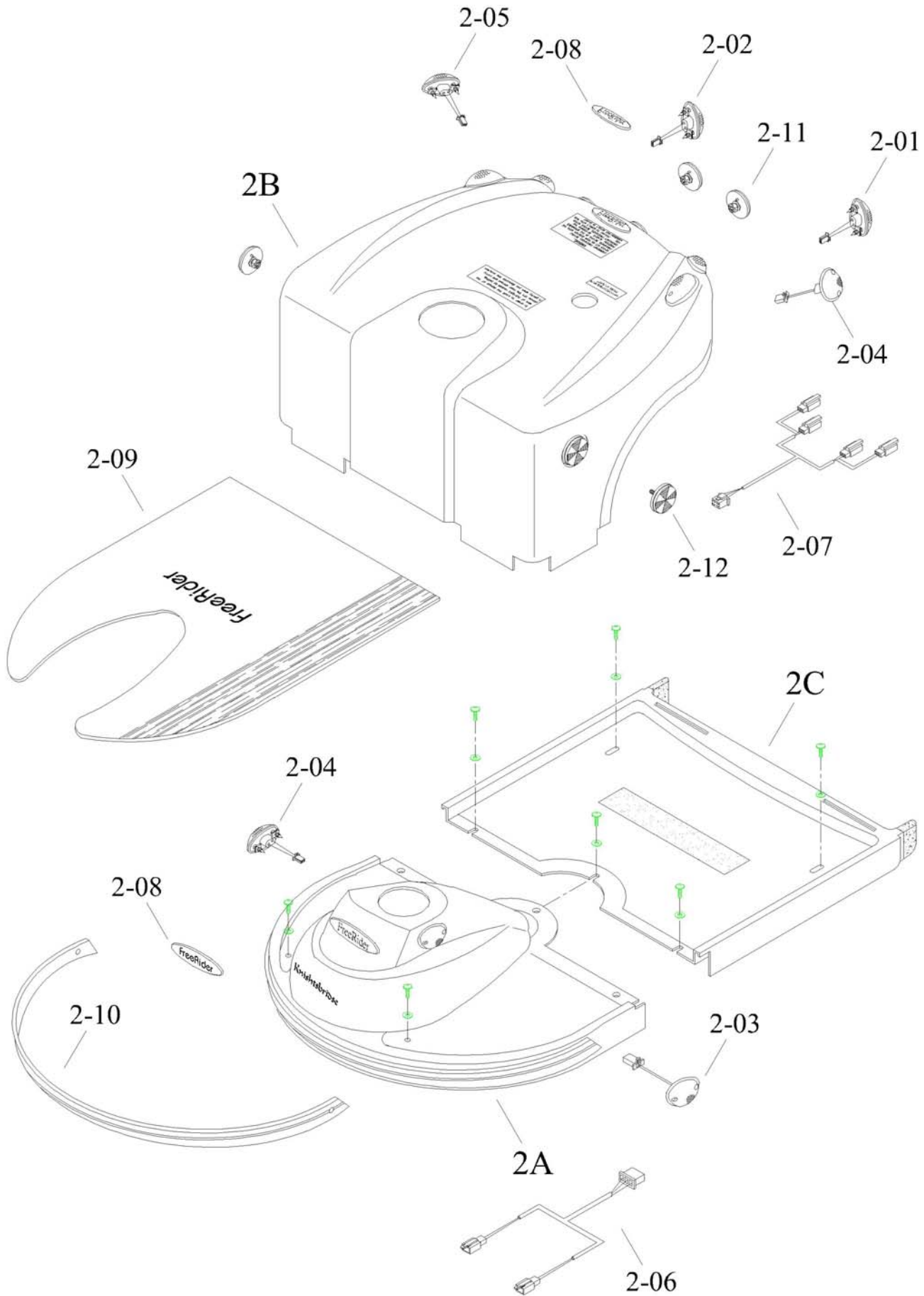

STEERING

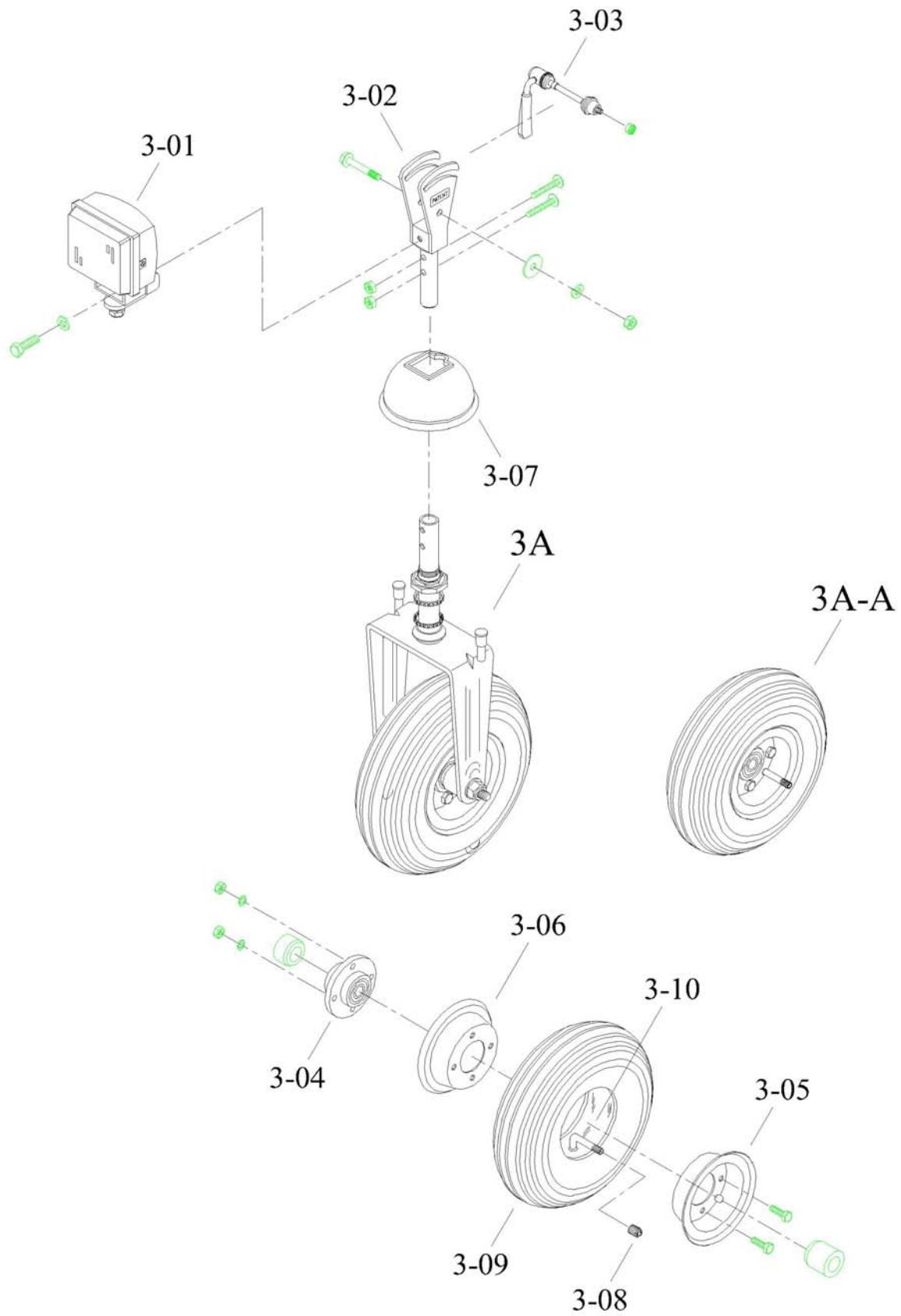

FRONT CHASSIS ASSEMBLY

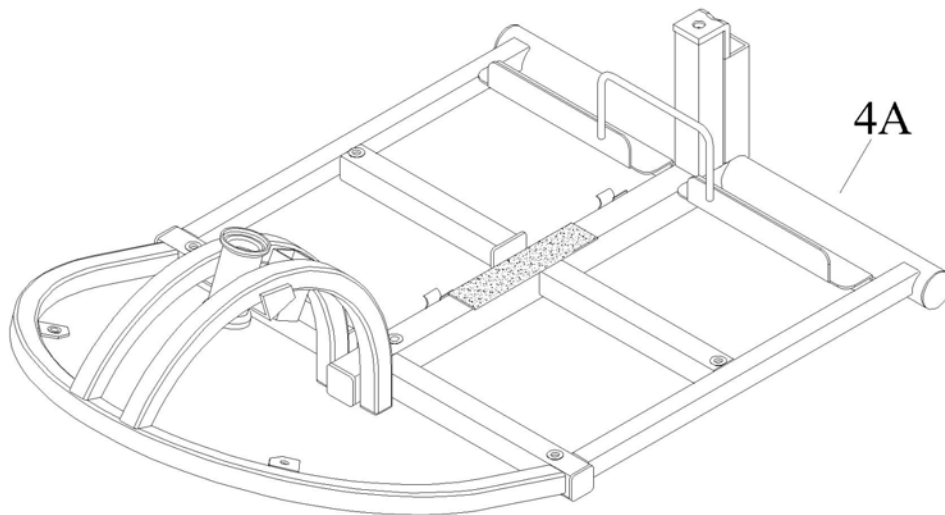

REAR CHASSIS ASSEMBLY-DRIVE SYSTEM

DRAWING NO.	PART NO.	PART NAME	€	GBP	USD
5A	AB07-0402-S	REAR CHASSIS ASSY.			
5B	AC11-1801	TRANS AXLE ASSY.			
5B-A	PA05-A124-A	350W/3600RPM MOTOR ASSY.			
5B-B	PA11-A900	TRANS AXLE ASSY			
5C	AC13-0400-GC	REAR WHEEL ASSY.			
5C-01	PM12-0300	INNER RIM (STEEL) 13"			
5C-02	PM12-0400	OUTER RIM (AL., BLACK) 13"			
5C-03	PM13-0104	D19 HUB (REAR)			
5C-04	PP92-0001	VALVE CAP			
5C-05	PP92-0401-GC	(4.10/3.50-5) TYRE			
5C-06	PP93-0401-C	(4.10/3.50-5) TUBE			
5D	PA06-A701	SEAT POST ASSY.			
5-01	PA06-B100	PRESSING SPIRAL SPRING ASSY.			
5-02	PKE2-0403	CIRCUIT BREAKER 35AMP			
5-03	PM07-0202	BRACKET			
5-04	PM11-0105-P	MAGNETIC BRAKE			
5-05	PM11-0401	MOTOR CARBON BRUSH			
5-06	PP06-0102	TUBBER COVER REAR FLAT			
5-07	PP06-0202	SEAT POST REAR FLAT			
5-08	PP07-0102	ANTI-TIP WHEEL SMALL			
5-09	PP11-0206	MOTOR CARBON BRUSH CAP			
5-10	PP90-0401	BATTERY FASTEN STRAP			
5-11	PV00-0702-1	7/16x8x48L BOLT			
5-12	PV06-0801	RELEASE TIGHTEN KNOB			
5-13	PA07-A900	STILT ASSY.			

SEAT ASSEMBLY

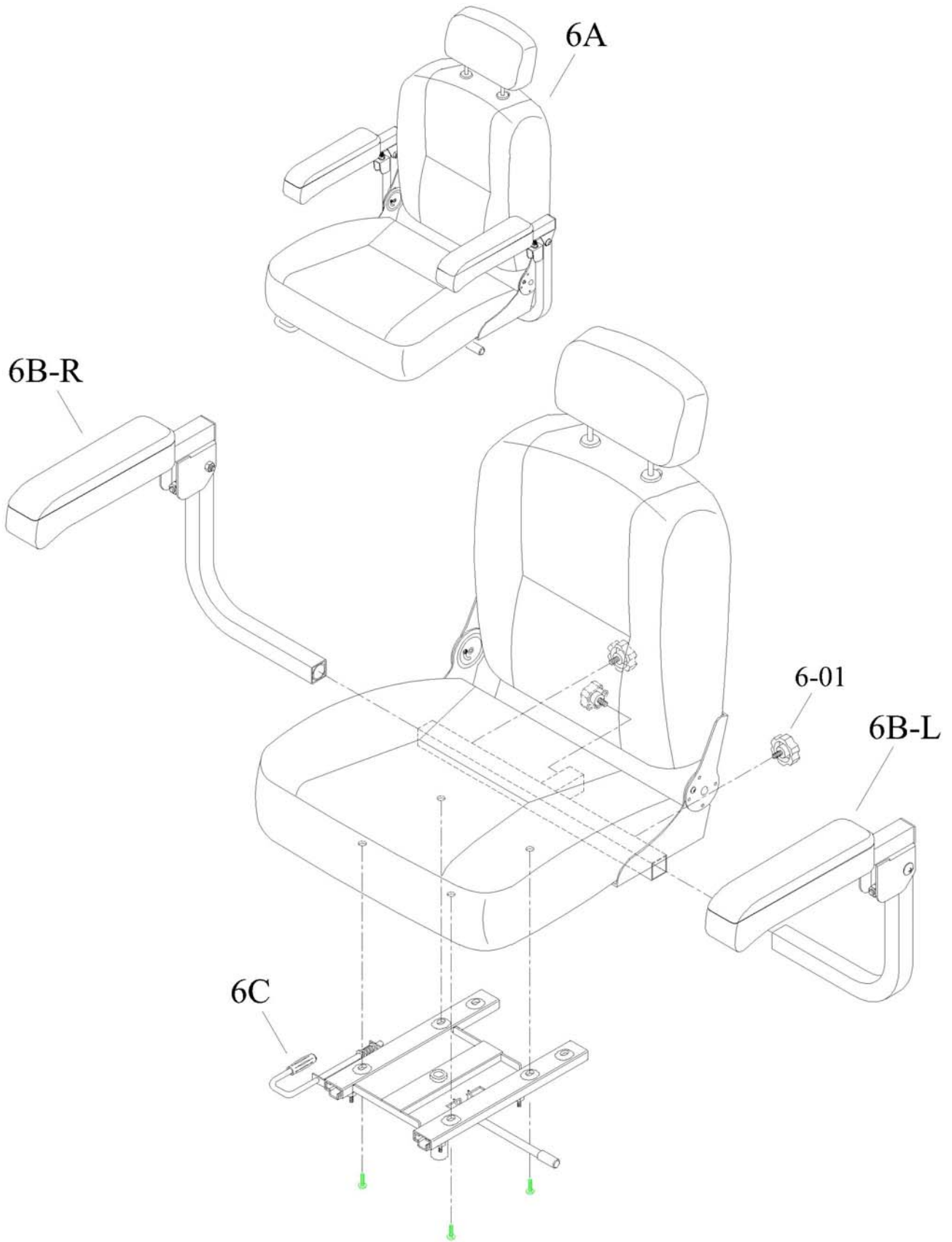

CONSOLE AND WIRING SYSTEM

