

# !CLICK-&-GO<sup>TM</sup>

Innovation in wheelchair power support systems

## Excel Click & Go powerpack

Technically advanced, easy to attach under your wheelchair and easily operable.

The Excel Click & Go is equipped with two-wheel drive and a microprocessor-driven programmable electronics. The unit fits under almost any foldable wheelchair through the use of a universal mounting kit.

The progressive qualities ensure that there is always enough grip. The motor is equipped with an automatic electro-magnetic brake, to ensure the users safety.

The Click & Go comes with as standard:

- Battery charger
- AccuSet including carrying case
- Manual operation cabinet
- Mounting instructions
- Adaptation plates
- Extension for push handles
- Assembly manual on CD ROM



The wheelchair that you wish to mount a Click & Go powerpack to must meet the following conditions:

- The space between the sideframes must be at least 34 cm
- The distance between the centre of the rear wheels and rear of the crossbrace must be at least 25 cm
- The wheelchair must have a circular horizontal tube of at least 19 mm to 25 mm diameter
- The clearance at the rear of the wheelchair must be at least 40 cm
- The wheelchair should be equipped with anti-tip wheels for safety



Easy to use! Mountable in just a few moments.



!CLICK-&-GO<sup>TM</sup>  
Innovation in wheelchair power support systems

Overall width: mounts onto wheelchairs with seat width 40-50 cm  
Overall length: 38 cm  
Overall height: 46 cm  
Drive Wheels: 200 x 50 mm

Weight (complete): 18 kg  
Weight (without batteries): 10 kg



Product complies with crash test EN12184

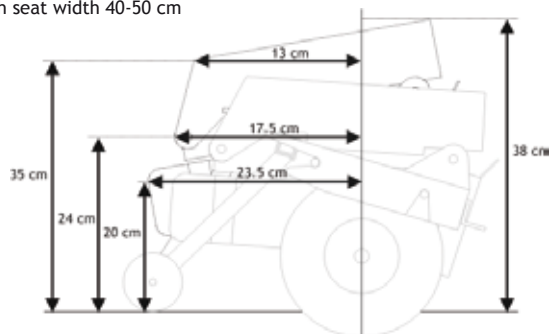

Van Os Medical UK Ltd  
42-44 Ousegate, Selby  
YO8 4NH

Tel.: +44 (0) 1757 701177  
Fax: +44 (0) 1757 706011

sales@vanosmedical.com