



User Manual

Excel

Navigator 3 'Compact'

'Smart mobility solutions'

Read instructions before use

Welcome aboard your new Navigator scooter!

We wish to thank you for letting us improve your freedom and independence. This model has been designed with your practical needs in mind. It is equipped with modern high tech electronics and special features for a more comfortable ride.

Its safety and performance will provide you with years of excellent service and pleasure!

It is from the utmost importance to read this manual very well before using the Excel Navigator scooter. The manual contains important information concerning the use and small maintenance of the Navigator. Safe use of the Navigator is a following issue. This manual should be stored very well. It contains information that might come in handy later!

The italic printed parts in this manual are from extra importance. They supply important information concerning safe use of you mobility scooter.

The Excel Navigator has also a service manual containing the electrical scheme, 3D drawings, parts lists and fault finding.

The intended use of the Excel Navigator is for people of all ages, who have trouble with walking far distances or walking for a longer time.

The Navigator is an outdoor use scooter. The seat can be adjusted by the user. The seat height can also be adjusted to lower leg length. The seat is able to turn and the flip backward armrests can be used for an easy transfer.

The maximum speed of the Navigator is about 15 km/h and at a normal daily use the range is up to 60 km (in combination with 73Ah batteries). The Navigator can be loaded up to about 150 kg. The electric engine is controlled by a control unit with micro processor. The electronic driving characteristics can be adjusted to your wishes within certain limits. Please contact your dealer in this case.

ATTENTION! INDIVIDUAL ADJUSTMENTS TO THIS PRODUCT NEED TO BE DONE WITH THE MANUFACTURERS WRITTEN APPROVAL.

Contents

Introduction

- Practice before use

Safety instructions

- Safety precautions

- Outdoor use

- Driving in hilly surroundings

Learning the scooter

- Scooter parts

- Charging the batteries

Use of the scooter

- Control

- Seat adjustment

- Tiller adjustment

- Freewheel lever

Specifications

Maintenance

Warranty

General safety precautions

The Navigator is designed to be safe in use. This can be noticed on the scooter directly in the below features:

- When charging the scooter it cannot be driven electrically
- At too high temperature of the engine or controller unit (Dynamic Rhino) the Navigator will drive at half power
- With the freewheel function engaged the scooter cannot be driven electrically
- If the control lever is in neutral position the scooter cannot be driven.
- Scooter parts where might be body parts clamped between are fully covered

The Navigator is meant to be used by one person. Placing a second person on the scooter is not allowed. The driving characteristics will be influenced badly by this and the Navigator will damage.

Inside the control unit (Dynamic Rhino) is a function build who prevents deep de-charge of the batteries. The control unit reduces the speed eminently.

Please make sure when driving the scooter and performing small maintenance to the Navigator there can be no fingers injured in the space between the covers and the wheels.

Driving inclines

A very safe control feature when driving inclines is the following: if the Navigator is able to drive an incline, the incline can also be descent with reduced speed. Always drive a steep incline up first and make sure the Navigator is not too heavily loaded.

Turning the Navigator on an incline is not recommended. The scooter can easily tip over.

Never drive from a pavement or incline diagonal. The scooter may tip over. Always drive off a pavement or incline at low speed.

In areas with pedestrians it is recommended to adjust the maximum speed to a lower standard for your and other persons safety.

Transport

Transporting the Navigator inside a vehicle can be done by making the scooter as small as possible. In this case, you dismount the chair and fold the tiller down. Always check if the scooter is not in freewheel mode and fixate is firmly to the floor.

It is recommended to not sit in the scooter during transport. The scooter should always be lifted by two persons, one at the front (front bumper) and one at the back of the scooter (rear bumper). Van Os Medical accepts no responsibility for any eventual consequences.

Freewheel mode

On freewheel engagement the brakes of the Navigator are not working. By disengaging the freewheel lever the brakes will be in work again. Look at page 17 for further freewheel explanation.

Never us the freewheel mode when standing on an incline. This may cause the scooter drive by itself.

Electro Magnetic Compatibility

A couple of European standards have been set in the field of electro magnetic interference on electric devices. The Navigator complies to these demands. In an extreme case the Navigator might be sensitive to very powerful transmitters. This may cause unexplainable faults. In this case you best turn to your dealer.

When using transmitters nearby the Navigator, we recommend to first shut down the scooter before using a device.

Examples of transmitters can be mobile phones, walkie talkies or a 27 MC transmitter. The Navigator itself also transmits electric waves. These are within the applying standards. There might be, however, certain unintended events, like a shop alarm going off.

Fixation belt (optional)

An optional fixation belt can be mounted to fix the seat position (picture 1). The two parts of the belt can be mounted below the seat with screws. The screws fixate the belt to the ground plate of the seat. By use of a click buckle the belt can be fixated.

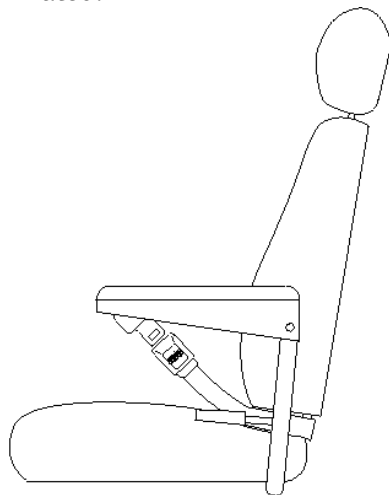

Picture 1

The fixation belt can only be used on the chair. During transport in a wheelchair taxi the fixation belt may not be used as a safety belt.

Responsibility

Van Os Medical B.V. can not be held responsible for unsafe situations, accidents or damages, as a result from:

- use for other purposes or under other circumstances than indicated in this manual. This also contains applying other than the original replacement parts and changing the programming adjustments of the Rhino controller
- ignoring warnings or precautions noted in this manual
- improper or insufficient maintenance

First use

Not following these safety guidelines may result in damage to the scooter or personal injury

Find an open area such as a park and make sure you have an assistant to help you exercise with the scooter (picture 2).

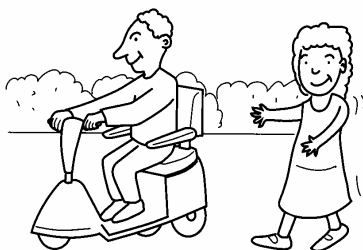

Picture 2

Make sure the scooter is off before getting in or out of it. Set the speed control knob according to your driving ability.

We recommend that you keep the speed at the slowest position (fully counter-clockwise) until you are familiar with the driving characteristics of this vehicle.

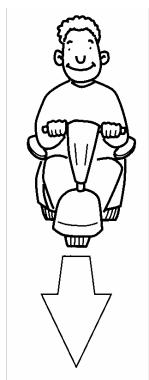

Picture 3

Learning the scooter

Now, practice moving forward by pulling the right lever. Be sure to set the speed to the lowest setting (1). After becoming familiar with moving forward, practice making 'S' turns (picture 4).

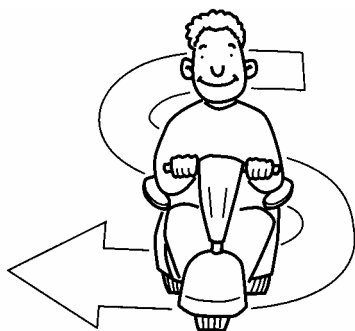

Picture 4

Once you are familiar with 'S' turns, practice moving in reverse. When driving backward the scooter already drives slower than forward, but for your safety we recommend to put the setting to the lowest level (1).



Picture 5

Pay attention to the following warnings!

Do not carry any passengers (picture 6)!



Picture 6

Do not drive across a slope (picture 7)



Picture 7

Never drink and drive (picture 8)!



Picture 8

Do not tow a trailer (picture 9)



Picture 9

Do not turn on or use hand-held personal communications devices such as citizens band (CB) radios and cellular phones.



Picture 10

When driving on the road, pay attention to the following:

Do not drive in heavy traffic (picture 11)

Do not drive beside a river, port or lake without a fence or railing (picture 12)

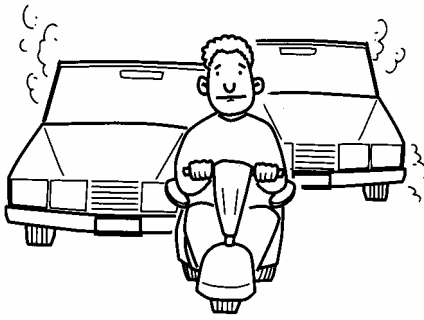

Picture 11

Do not drive during the rain (picture 13)



Picture 13

Do not drive off-road or on any Uneven surfaced roads (picture 15)



Picture 15

Make sure that there are no obstacles behind you when driving in reverse
We recommend to set the speed knob at the lowest speed (1) when driving back (picture 17)

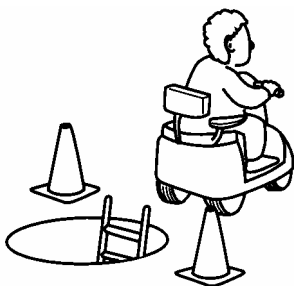

Picture 17



Picture 12

Do not drive during or on snow (picture 14)



Picture 14

Be sure to use headlights when driving at night (picture 16)



Picture 16

Do not make sudden stops, weave erratically, or make sharp turns (picture 18)



Picture 18

Keep your hands on or inside the armrests and feet on the footplate (picture 19)

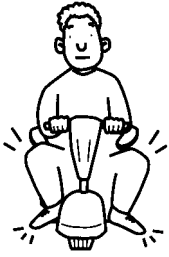

Picture 19

Do not attempt to cross over a gap greater than 10 cm (picture 21)

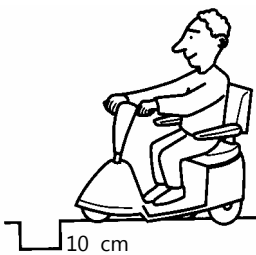

Picture 21

Do not reverse while driving up a hill Forward only. If you reverse while moving Uphill, it may cause the vehicle to tip over (picture 23)



Picture 23

Use low speed while driving downhill. When going downhill, the tiller will become harder to reach and handle. When braking while moving downhill the scooter will take longer to come to a complete stop (picture 25)

Do not attempt to climb curbs greater than 5 cm (picture 20)



Picture 20

Do not attempt to climb a hill greater than 10° (picture 22)



Picture 22

Use caution when driving over soft, uneven or unprotected surfaces such as grass, gravel and decks (picture 24)



Picture 24

Do not get in and out on a hill Always stop on the level surface to get in and out of the vehicle (picture 26)

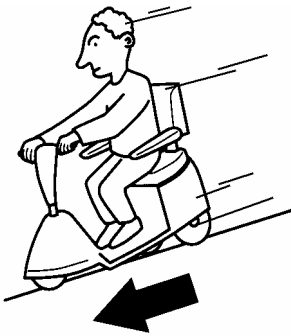

Picture 25

Always climb or descend gradients perpendicular to the slope or ramp (picture 27)

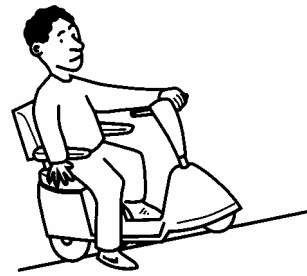

Picture 26

Do not load or carry heavy items in the basket while driving downhill (picture 28)

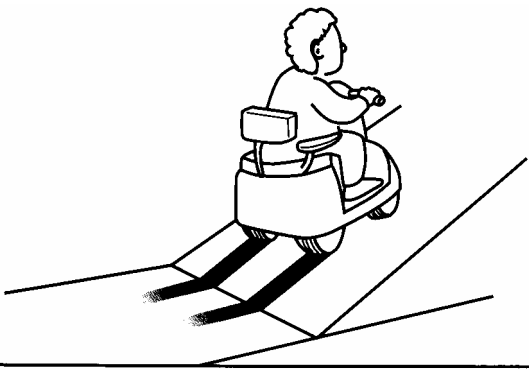

Picture 27

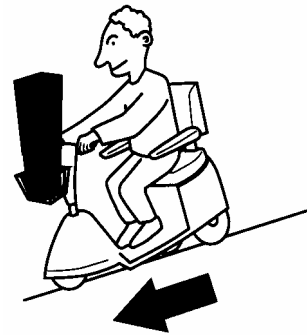

Picture 28

Control units

The control units of the Navigator are very clearly arranged on the dashboard (picture 29). The charging plug is located on the tiller, the freewheel lever on the rear right side of the scooter. The status indicator is located on the dashboard. See the below picture for a survey of all control units.

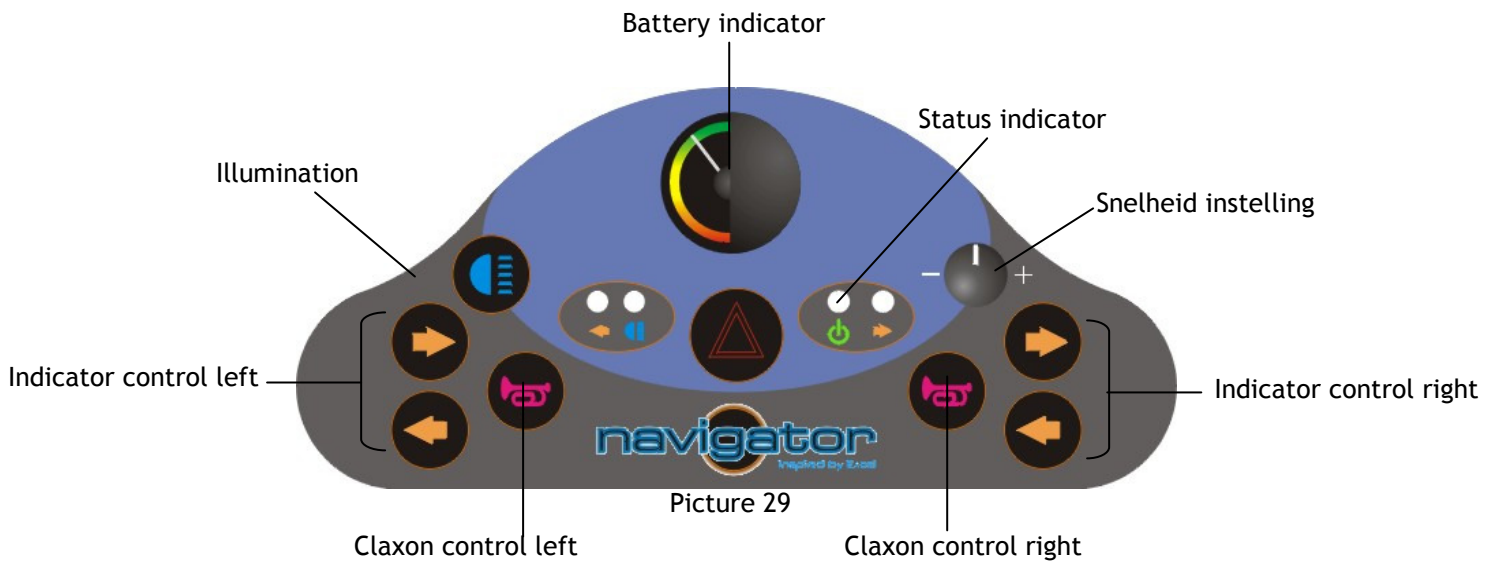

The control lever (gas lever, picture 30)

Pull the left lever to drive backwards

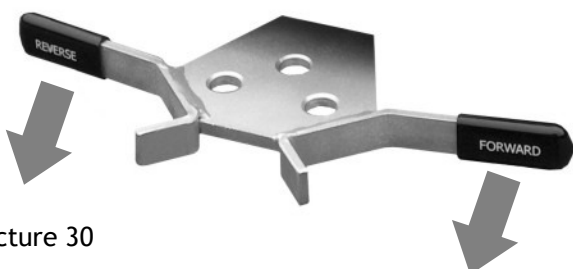

Pull the right lever to drive forwards

Picture 30

Battery indicator

This indicates the battery charging amount (picture 31). This also affects the range at the time. The indication is divided as below:



Full range
(90% - 100% capacity available)



Decreasing range
(60-70% capacity available)

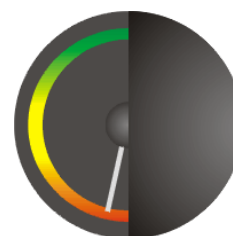

Limited range
(20-30% capacity available)

Picture 31

Warning lights

Warning lights can be powered by pushing the button. By pressing it again, the warning lights will go off.

Indicators

The switches can be pushed to engage the indicators. They can be operated both left and right handed.

Horn

Pressing the button engages the horn.

Speed adjustment

This knob adjusts desired maximum speed. You turn the knob right for a higher maximum speed and left for a lower. Speed can be adjusted in 6 steps.

Status indicator

When scooter is powered and no technical problems are at hand, the indicator will lit up. If a specific part of the electronics need maintenance or attention the indicator will blink a certain amount of times. See the reference list below for the different code meanings.

NUMBER OF BLINKS	FAULT	SCOOTER CONDITION	REMARKS
1	Charge battery	DRIVING POSSIBLE	BATTERY VOLTAGE LOWERED TO LESS THAN 23.3 V, CHARGE BATTERIES SOON
2	Battery voltage too low	DRIVING NOT POSSIBLE	BATTERY VOLTAGE LOWERED TO LESS THAN 16.5 V, CHARGE BATTERIES IMMEDIATELY
3	Battery voltage too high	DRIVING NOT POSSIBLE	BATTERY VOLTAGE INCREASED TO HIGHER THAN 32 V. PROBABLY DEFECT CHARGER
4	Current time limit out	DRIVING NOT POSSIBLE	DETECTOR DETECTED SHORTCUT IN THE MOTOR. WARN DEALER
5	Brake fault	DRIVING NOT POSSIBLE	CHECK IF FREEWHEEL IS DISCONNECTED
6	Gas pot not in neutral at power up	DRIVING NOT POSSIBLE	CONTACT DEALER
7	Speed pot error	DRIVING NOT POSSIBLE	CONTACT DEALER
8	Motor volts error	DRIVING NOT POSSIBLE	CONTACT DEALER
9	Other internal error	DRIVING NOT POSSIBLE	CONTACT DEALER

Charge plug

To charge the batteries use a charger which guards the process and is convenient to charge the fitted batteries. Your battery charger should be equipped with a 3-pole plug which fits into the charging plug in the tiller.

Making a transfer

Make sure the Navigator is always turned off and in freewheel position before making a transfer.

- move the rotation lever upwards to unlock the chair (picture 32)
- next, turn the chair 90° left or right. The chair will automatically lock on every 45° if you release the rotation lever (picture 33)
- take place on the chair and turn it back to the starting position. The chair is fitted with flip-backward armrests. These can be flipped away to be able to make an easy side transfer. Always make sure to flip the armrests back in the original position when seated.

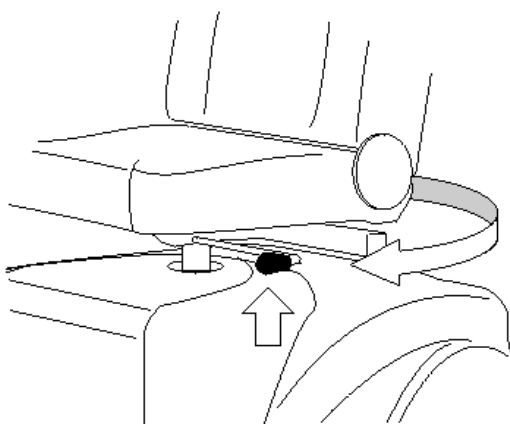

Picture 32

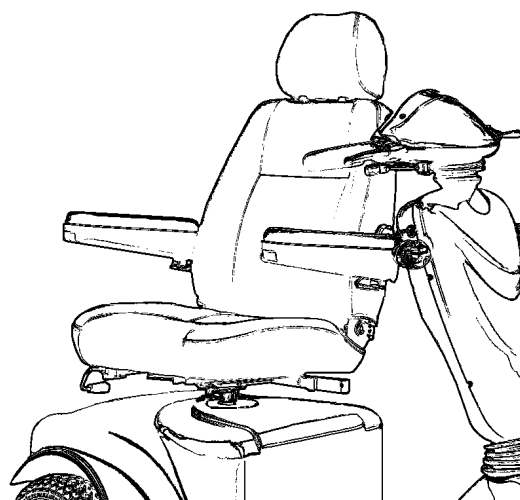

Picture 33

Driving

The Navigator can be powered up with the ignition key on the right side of the tiller. After a brief self-test the Navigator is ready to drive. By pulling the right side of the gas lever (at thumb control pushing), the Navigator moves forward. The closer you pull the lever towards you, the faster the scooter will drive. If you release the lever the Navigator will stop. For reversing please stop the scooter first. Now pull the left side of the gas lever (a thumb control push). The Navigator now will drive backwards, with reduced speed.

Before you drive, first check if the chair is properly fixated.

Make sure the tires are always on the right pressure (see technical specifications).

Make sure the batteries are always sufficiently charged. The pointer of the battery indicator should be in the green area.

Should the gas lever not be in neutral position when the Navigator is powered up, it will not drive. Only after the control lever has been placed in neutral position, the Navigator is ready to drive. The neutral position is when the gas lever is not operated.

Never take sharp turns while driving at full speed. We recommend to slow down before making a sharp turn. The Navigator is equipped with a sensor which will decrease the speed with 50% when turning. We strongly recommend to avoid dangerous driving in corners.

Always think of your own safety if you drive from the even road with the Navigator. Adjust your speed. Never drive through deep holes, water etc.

The ideal stability and weight balance can be achieved when taking the following points into consideration: always sit straight on the chair and place your feet as far to the front as possible. Do not lean left or right while driving.

Driving on an incline

A very safe control feature when driving inclines is the following: if the Navigator is able to drive an incline, the incline can also be descent with reduced speed. Always drive a steep incline up first and make sure the Navigator is not too heavily loaded.

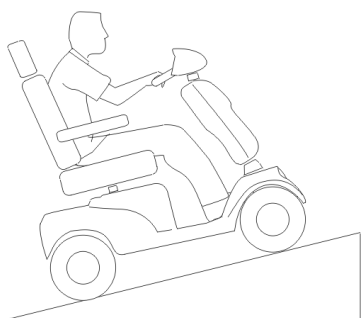

Picture 34

Driving up a hill: lean a little forward and drive as constant as possible in a straight line up (picture 34). To stop and restart driving costs extra energy.

Driving off a hill: lean a little backward and drive carefully with low speed down the hill.

A will which is difficult to climb for the Navigator needs to be avoided. When climbing very steep inclines (over 12°) is dangerous. At sudden braking the scooter might tip over to the front or the back.

Obstacles and thresholds

Driving obstacles should be done very carefully. When driving an obstacle which is too high the Navigator might get stuck. For maximum ground clearance please see the chapter 'Technical data'.

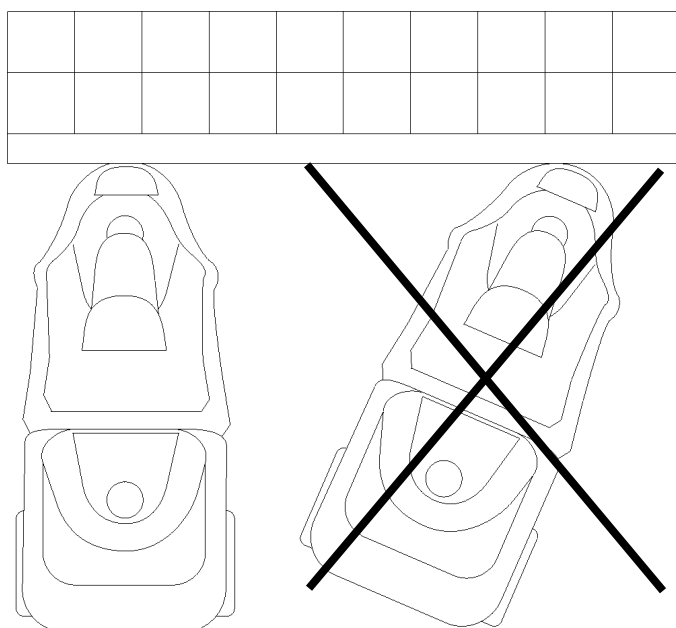

Picture 35

Driving up thresholds: drive towards the threshold until the front wheel is approximately 20-50 cm before the threshold. Now carefully drive forward and approach the threshold. As soon as the front wheel is on the threshold you can slowly drive further until the rear wheels are also on or over the threshold (picture 35). If this does not succeed or very difficult, please choose another route.

Driving off thresholds: drive to the threshold until the front wheel is before it. Drive off the threshold carefully and with low speed.

Brakes

Braking can be done in different ways:

- you can slowly move the gas lever into the neutral position, to make the Navigator slow down easily
- you can just let the gas lever go, so the Navigator will come to a full stop
- the Navigator is also fitted with a disk brake rear with the lever on the tiller. This may be used on eventual emergency stops

If driving down a hill the Navigator might drive faster than the maximum speed possible. In this case the control unit will slow the Navigator down to reach the programmed maximum speed.

If the gas lever of the Navigator is in neutral position the scooter is braked. The motor brake power is enough to stop the scooter and keep on its place on the maximum possible incline angle (12 degrees).

At rain, snow or other slippery road conditions, please brake gently to provide sliding danger.

Battery safety

When driving on low or empty batteries, to be seen on your battery indicator, the battery safety feature will be engaged. This provides battery damage through deep discharge. The engagement of this feature can be noticed by the decreasing maximum speed. Drive as little as possible in this condition. After thy system being engaged the batteries should be charged as soon as possible.

Freewheel

The Navigator is equipped with a so-called freewheel function. This allows the Navigator to be moved without using the engine. Push the backrest to move the scooter. In this freewheel position the scooter can not be driven electrically. You can engage the freewheel function by the freewheel lever on the rear side of the scooter, just below the cover (picture 36).

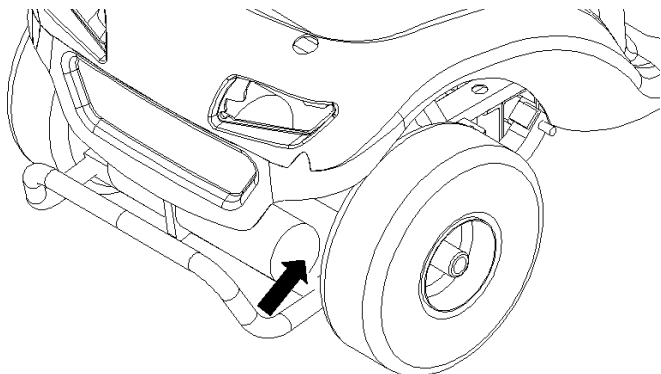

Picture 36

It is important to first fully turn off the power before engaging the freewheel lever. The power needed to push the scooter is minimal. The brakes of the Navigator are not in use during freewheel engagement. This can be reversed by turning the freewheel function off.

Fault by engaged freewheel

If the Navigator is powered when you engage the freewheel lever, the status indicator will indicate fault code 5. To erase the fault code and drive electrically please proceed as follows:

- first disengage the freewheel function (push the freewheel lever down)
- then, power off the system (this erases the fault)
- when the system is powered up the scooter is able to drive again

The Navigator chair

The chair of the Navigator is equipped with a number of adjustment possibilities which improves your seat and driving comfort considerably. The entire chair can be height adjusted in a range of 10 cm in 4 steps of 2,5 cm. This adjustment can be done by your dealer.

Adjust backrest angle

The backrest angle is stepless adjustable in a sitting position up to standard 105 degrees (picture 37). By replacing the hex bolt on the turning point this can be increased up to 135 degrees. The backrest can also be fully flipped forward to ease transport. On the right side of the chair (left shown on picture 37) is a lever. Pull it up and lean forward or rearward to adjust the desired backrest angle (picture 37). As soon as you reached it you release the lever> The backrest will fixate in your position.

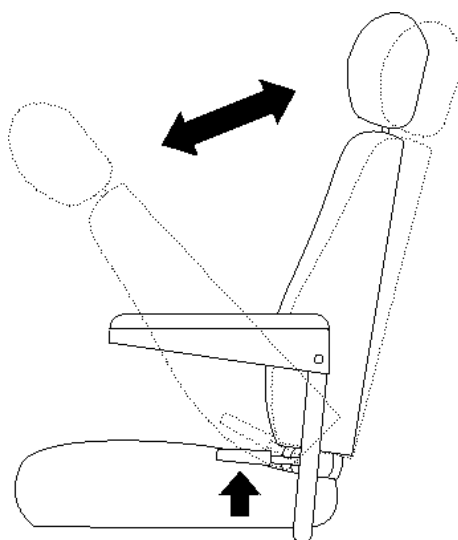

Picture 37

Never operate the lever when you are not in the chair. The backrest will come forward with strength.

Adjust lumbar support

The chair is equipped with a lumbar adjustment in 4 steps, adjustable through a turning knob on the side of the backrest. This creates more or less support in the lower back. After adjusting position 4 (maximum) the adjustment automatically falls back in position 1 (minimum) when the knob is turned further (picture 38).

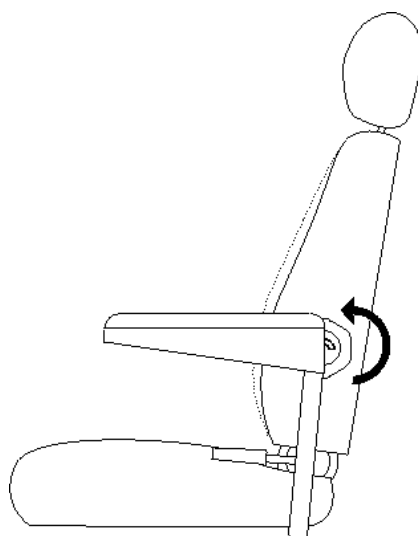

Picture 38

Armrest adjustment

The armrests can be fully flipped up (picture 39). Also the angle and the armrest height are adjustable. The armrests are fully flipped up by moving them up. The armrest angle is adjustable by the bolt on the inner side of the armrest. You can turn this bolt further out by hand (the arm rest angle will go down) or further in (the arm rest angle will go up). On the rear side of the arm rest tube is a turning knob. Turn it loose and adjust the arm rest to the desired height. Fasten the knob securely.

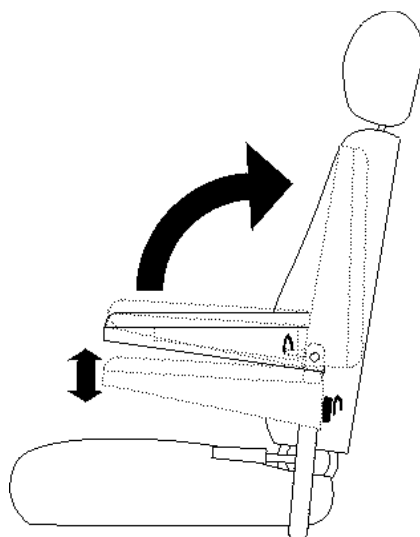

Picture 39

Adjust head rest (option)

The head rest is adjustable in three height positions.

Removing the Navigator chair

Unlock the turning system of the chair as shown on the picture below (picture 40). You can pull the chair straight up and eventually move it around a little. Flipping back the armrests and folding down the backrest eases the removal.

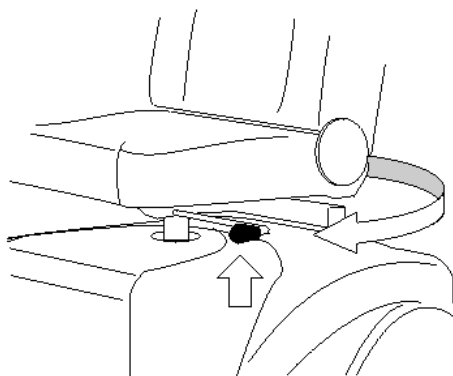

Picture 40

The chair of the Navigator weights around 16 kg. Please remember this when removing the chair. The chair can be lifted by putting your one arm around the backrest and grip firmly and the other arm under the seat. Folding the armrests and the backrest can ease the lifting.

Adjust tiller

You can adjust the tiller angle as follows (picture 41):

1. pull the small lever on the left side of the tiller
2. you can adjust the tiller with two hands by lowering or lifting it in the desired position
3. when you release the lever the tiller will fixate in the current position
4. the tiller can be fully folded down to ease transport

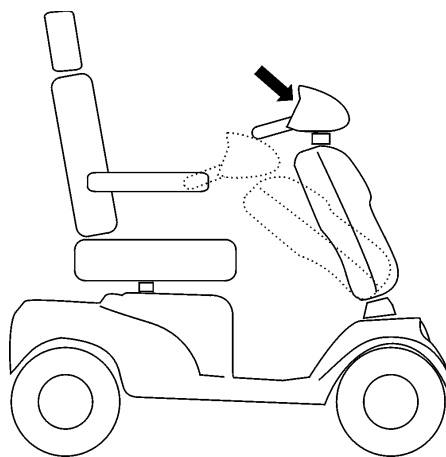

Picture 41

Moving the Navigator manually

Manual movement of the Navigator can be done by first engaging the freewheel mode and the power off. If this is not done the Navigator can only be moved with great strength.

- put the freewheel lever in the up position. This engages the freewheel mode
- the Navigator can now be moved freely by pushing the backrest
- after returning the freewheel lever and powering up the control unit the Navigator is able to drive again.

The brakes of the Navigator are not in use during freewheel engagement. This can be reversed by turning the freewheel function off.

Fault by engaged freewheel

If the Navigator is powered when you engage the freewheel lever, the status indicator will indicate fault code 5. To erase the fault code and drive electrically please proceed as follows:

- first disengage the freewheel function (push te freewheel lever down)
- then, power off the system (this erases the fault)
- when the system is powered up the scooter is able to drive again

Charging the batteries

The Navigator can be equipped with two dry 12 Volt batteries of maximum 73Ah. At daily use the dry batteries need no other maintenance than regular charge. The capacity of the batteries at 5 hours discharge is 70 Ah, at 20 hours discharge 75Ah. The scooter is equipped with 2 Trojan type SG 70 B batteries. The battery connector type on the cable is Alex PVC, dimensions 40 x 20 mm.

Because the batteries are probably empty or partly charged when they arrive, it is of great importance to first fully charge the batteries. The scooter is fitted with a charger, standard delivered. If the batteries are charged using the below procedure, you will gain maximum lifetime, power and reach of the batteries.

1. Turn off the power of your scooter
2. Put the power support cable in a wall socket

3. Put the battery charge cable into the tiller (turn away the round cover) (picture 42).
4. When the battery charger is turned on the scooter will be charged. During charge the progress indicator will blink. A RED light means the charger is in use, a WHITE light means the scooter is being charged and a GREEN light means the scooter is fully charged.

The Navigator can not be driven electrically with a plug in the charge socket. If the range of the Navigator is strongly decreasing, the batteries need replacement. In this case you need to contact your dealer. It is not allowed to replace the batteries yourself. When a battery is leaking contact dealer immediately! Please consider the following when changing batteries: see that the connectors do not contact with each other. Make sure when connecting the batteries the connectors are correctly poled (++ and --). The Navigator comes with a battery charger. If any problems occur please contact your dealer. It is not allowed to open the charger. The charge socket is indicated with a symbol on the tiller (picture 42a). The charger connection is indicated on the charger with a symbol (picture 42b):

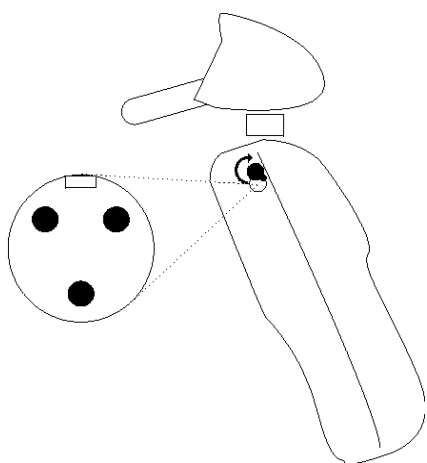

Picture 42

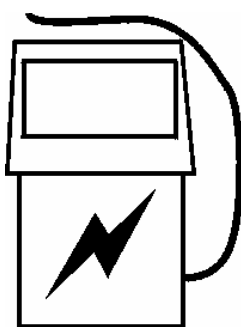

Picture 42a

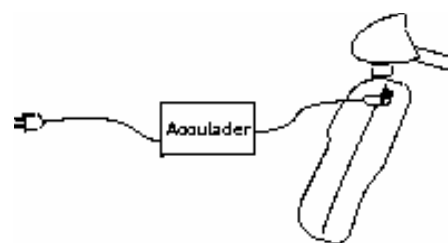

Picture 42b

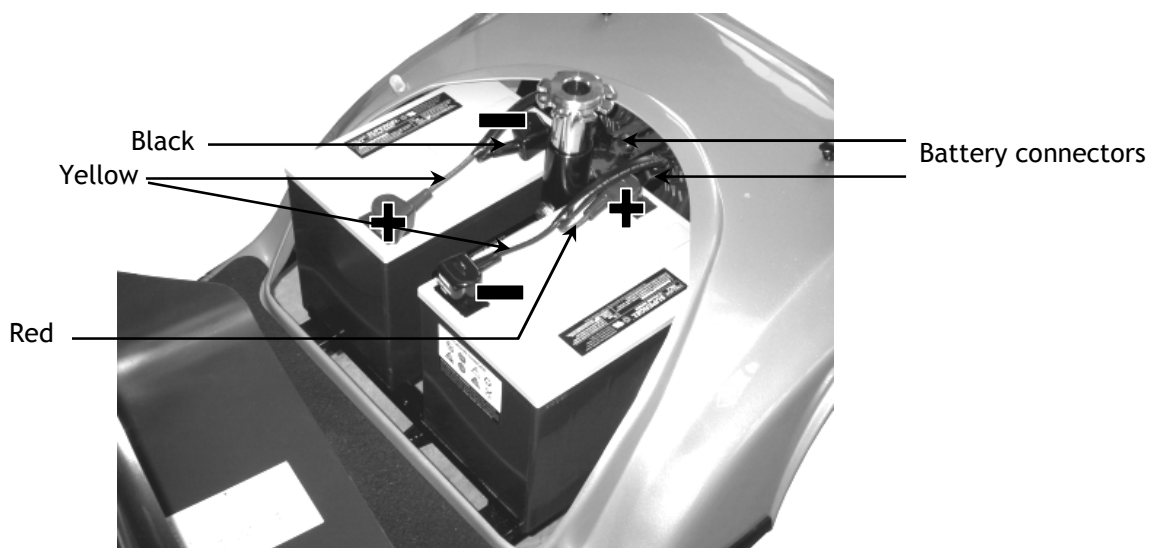

Picture 42c

Battery charger specifications:

- appropriate for the fitted batteries
- maximum nominal charge current: 24 Volt
- maximum nominal charge power: 6 Ampère
- suitable for unguarded use

Opening battery space

The batteries of the Navigator can be reached by removing the battery cover (picture 43). First remove the chair as described on page 17. The battery cover can be removed by loosening the hex bolt on the cover and taking the cover off. Replacement in reverse order. The batteries should be lifted on the lower side.

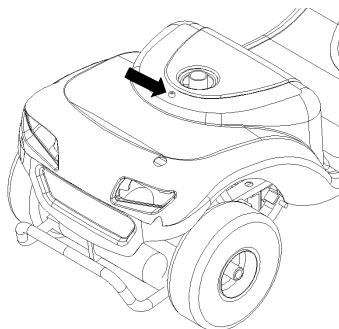

Picture 43

Storage

If the Navigator is not be used for longer time, please consider the below remarks. The Navigator needs to be stored with fully charged batteries in a dry and freeze free environment, in regard to freezing danger of the batteries. Always turn the Navigator off during storage.

The charge condition of the batteries should be checked regularly when the Navigator is not used for a long time. If necessary the batteries must be recharged.

The Navigator should never be left unnecessary in the bright sunlight. Parts like the upholstery or metal parts might get very hot. This also might shorten the tyres lifetime.

Upholstery

The scooters upholstery should be cleaned with a mild cleanser. Weep the upholstery should with a moist cloth after cleaning.

Chasis and plastic parts

The chasis and the plastic parts, including the control panel, should only be cleaned with a light moist cloth. Dry the parts after that with a dry cloth.

It is not allowed to clean the Navigator with a high pressure hose or otherwise using too much water.

All the maintenance that can be done by the user is described in this chapter. If the Navigator needs additional maintenance or repair you need to contact your dealer. It is not allowed to perform any other than the herein described tasks on the Navigator.

Charging the batteries

Always charge the batteries regularly and on time. This preserves the maximum charge capacity and increases the lifetime of the batteries. For charging instructions see page 18.

Tires

It is very important to check the tire pressure or tire damage regularly. When any damage might occur (for instance caused by a nail or glass), contact your dealer immediately. The scooter tires should always be on the prescribed pressure (see chapter technical data). Driving with low pressure tires causes bad driving and steering characteristics.

The tires should never be inflated over the maximum tire pressure. The tire might get off the rim or explode.

Other maintenance

Please leave any other maintenance to your dealer. Adapt the needed maintenance to your scooter together with your dealer.

If any lubricant should leak, for instance from the gear box, please contact your dealer immediately and don't drive the scooter again.

Replacement parts

All Navigator parts, including electronic components, are securely adapted to each other and tested. This results in a quality scooter with a long lifetime. This quality, safety and lifetime can only be preserved by using only original replacement parts.

Not using original parts could result in decreased liability from the Navigator and reduced safety. Also due of the warranty.

All replacement parts can be ordered by your dealer at Van Os Medical B.V..

Maintenance frequency

This schedule has been made to give you a survey of the maintenance that should be done to the Navigator. The yearly maintenance should be done by your dealer.

Check	Weekly	Monthly	Yearly	By whom
Battery charger connection			✓	Dealer
Bolts and nuts			✓	Dealer
Tire wear		✓		User
Tire pressure	✓			User
Wiring and connections			✓	Dealer
Clean upholstery		✓		User
Illumination and indicators	✓			User
Bearings			✓	Dealer
Engine			✓	Dealer
Battery poles		✓		Dealer
Clean chassis parts and covers		✓		User
Driving program			✓	Dealer
Suspension			✓	Dealer
Freewheel and parking brake			✓	Dealer

Faults

The dashboard contains a status indicator. If this lights up green without blinking the Navigator is ignited and there are no problems. In case of a fault the status indicator indicates a fault by blinking codes. If the status indicator shows a fault, the first thing to do is turn off the power of the Navigator and ignite again.

If the indicator shows another fault, please count the blinks. These show a code which indicates a fault. The flash code list below shows all the meanings of the flashes. The list also contains possible causes and an eventual solution of the problem. If you are unable to solve the problem with help of this list, please contact your dealer.

NUMBER OF BLINKS	FAULT	SCOOTER CONDITION	REMARKS
1	Charge battery	DRIVING POSSIBLE	BATTERY VOLTAGE LOWERED TO LESS THAN 23.3 V, CHARGE BATTERIES SOON
2	Battery voltage too low	DRIVING NOT POSSIBLE	BATTERY VOLTAGE LOWERED TO LESS THAN 16.5 V, CHARGE BATTERIES IMMEDIATELY
3	Battery voltage too high	DRIVING NOT POSSIBLE	BATTERY VOLTAGE INCREASED TO HIGHER THAN 32 V. PROBABLY DEFECT CHARGER
4	Current time limit out	DRIVING NOT POSSIBLE	DETECTOR DETECTED SHORTCUT IN THE MOTOR. WARN DEALER
5	Brake fault	DRIVING NOT POSSIBLE	CHECK IF FREEWHEEL IS DISCONNECTED
6	Gas pot not in neutral at power up	DRIVING NOT POSSIBLE	CONTACT DEALER
7	Speed pot error	DRIVING NOT POSSIBLE	CONTACT DEALER
8	Motor volts error	DRIVING NOT POSSIBLE	CONTACT DEALER
9	Other internal error	DRIVING NOT POSSIBLE	CONTACT DEALER

All Van Os Medical products are built for a long and durable lifetime. However, during time reparation and maintenance to your Navigator will not be remunerative any more. Your dealer will contact you in time for this. When recycling the Navigator you should consider the below points:

- at scooter recycling the current or local precautions should always be followed
- the Navigator only contains known materials. A couple of these materials, if collected separately, can be recycled
- at development and build of the Navigator for all used materials known waste disposal possibilities and no risks were known for recycling persons, not containing the batteries

Make sure during recycle of the Navigator the batteries do not get damaged. They should be offered to a certified instance or company for further disposal. When dealing with batteries always take the needed precautions for protection of yourself and the environment.

Technical data

Type indication: Excel Navigator
15 km/uur electroscooter

Manufacturer: Van Os Medical B.V
Nijverheidsweg 4-6
4675 PX Sint Philipsland
The Netherlands

Technical data according to ISO 7176-15

Dimensions ready to drive (lxbxh):	1370x680x1320
Dimensions minimum (lxbxh):	370x680x1090
Total weight without batteries:	± 99 kg
Total weight with batteries:	± 145 kg (with 73Ah accu's)
Mass removable part:	± 16 kg
Static stability downhill:	12°
Static stability uphill:	12°
Static stability sidehill:	12°
Dynamic stability uphill:	12°
Maximum safet incline:	12°
Range:	60 km*
Maximum obstacle height:	100 mm (forward with distance)
Maximum threshold driveoff:	100 mm
Ground clearance:	100 mm
Maximum adjustable forward speed:	15 km
Maximum adjustable rearward speed:	5 km
Minimum braking distance from maximum speed:	3,3 meter
Seat angle:	3°
Seat depth standard seat:	460 mm
Seat width standard seat:	500 mm
Seat height minimum:	640 mm from the floor (steps of 25 mm)
Seat height maximum:	740 mm from the floor
Back rest angle (adjustable):	105 - 135° fixated
Backrest height:	490 mm
Armrest height:	200 - 300 mm
Front side armpad to front side backrest:	315 mm
Turning radius:	2300 mm
Testdummy weight:	150 kg
Maximum user weight:	150 kg
Control power:	1 N at hand control
Intended use:	Outdoor, Class C
User area:	European climate

* At average use in combination with dry batteries 73 Ah

The scooter further fulfills the following standards:

ISO 7176- 8: demands and testing methods for static, shock and fatigue strength

ISO 7176- 9: climate tests for scooters

ISO 7176-14: drive and control units for scooters

ISO 7176-16: demands for burn resistance

Other technical data

Battery space(lxbxh): (2x) 385x285x210 mm

Mass of batteries: ± 23 kg per piece (dry batteries 75 Ah/20)

Elektronic control: Rhino 110

Engines: 24 VDC, 230 Watt, 4000 rpm

Wheel size front: 4.00 - 5

Wheel size rear: 4.00 - 5

Tire pressure (front) : 50 PSI

Tire pressure (rear) : 50 PSI

Minimum battery capacity: 50Ah

Range

The range of the Navigator (± 60 km) depends on the following factors:

- condition of the batteries
- weight on the chair (user, luggage etc)
- average driving speed
- driving style
- surface
- environment temperature
- driving conditions (hilly or flat, gravel or smoot asphalt)

Standard programmed driving parameters

The Navigator controller is equipped with a microprocessor. This can be indicated as the 'brain' of the scooter. Inside this microprocessor a number of parameters can be adjusted. Some of these parameters have consequences for the driving characteristics of the Navigator. Van Os Medical B.V. equipped the Navigator with a standard program. If this program does not satisfy you, it can be adjusted by use of a programmer box to adjust all parameters to your desires.

The values of the parameters have been carefully chosen. Extreme altering of the parameter data could result in unstable driving habit. Small changes of the parameters are allowed.

Below a table is noted with the standard adjustments of the driving program:

Acceleration	3
Deceleration	9
Maximum speed	255
Forward speed	9
Rearward speed	4
Reduced speed	5
Horn volume	10
Engine resistance	15
Energy saving feature	30
Maximum peak	110
Soft start period	50
Parking brake slowdown	6
Neutraal pot gas lever	128
Standard Speed pot FSD	63
Standard speed pot dead band	20
Alternative Speed pot FSD	63
Alternative speed pot dead band	20

Warranty precautions

These warranty precautions are in accordance with all other product specific warranties and are just applicable to the first owner. If a none specified, to the product belonging warranty claim will appear, this claim will judged by Van Os Medical B.V. during the warranty period. During the warranty period the replacement parts can only be guaranteed until the end of the regular warranty period. All appearing warranty will be limited to the replacement or reparation of the defect parts. Van Os Medical B.V. can never be held responsible for any consequence such as damage or incidental damage, in what way ever.

Van Os Medical B.V. only guarantees replacement parts.

This warranty gives you specific lawful rights. You must be aware of the fact that these rights can change from country to country. Some lands do not accept a limited warranty concerning incidental or consequential damage, or the time limit of the warranty. In that case the warranty period and / or the exception of the warranty will be adjusted.

For warranty and service you need to contact the authorised Travelux® dealer, who supplied the Travelux®. If during a warranty period reparations are done by another company than Van Os Medical B.V. or a not by Van Os Medical B.V. approved company, every right on warranty comes to an end. In case of service and warranty is not given to satisfaction by your dealer, please contact Van Os Medical B.V. We will try to get to a satisfying solution for both parties.



Inspired by Excel

Van Os Medical B.V.
The Netherlands
Nijverheidsweg 4-6
4675 PX Sint Philipsland
Tel: +31 (0) 167 57 3020
Fax: +31 (0) 167 57 3381
info@vanosmedical.com
www.vanosmedical.com

Dealer:

Technical data

Type indication: Excel Navigator
15 km/uur electroscooter

Manufacturer: Van Os Medical B.V
Nijverheidsweg 4-6
4675 PX Sint Philipsland
The Netherlands

Technical data according to ISO 7176-15

Dimensions ready to drive (lxbxh):	1370x680x1320
Dimensions minimum (lxbxh):	370x680x1090
Total weight without batteries:	± 99 kg
Total weight with batteries:	± 145 kg (with 73Ah accu's)
Mass removable part:	± 16 kg
Static stability downhill:	12°
Static stability uphill:	12°
Static stability sidehill:	12°
Dynamic stability uphill:	12°
Maximum safet incline:	12°
Range:	60 km*
Maximum obstacle height:	100 mm (forward with distance)
Maximum threshold driveoff:	100 mm
Ground clearance:	100 mm
Maximum adjustable forward speed:	15 km
Maximum adjustable rearward speed:	5 km
Minimum braking distance from maximum speed:	3,3 meter
Seat angle:	3°
Seat depth standard seat:	460 mm
Seat width standard seat:	500 mm
Seat height minimum:	640 mm from the floor (steps of 25 mm)
Seat height maximum:	740 mm from the floor
Back rest angle (adjustable):	105 - 135° fixated
Backrest height:	490 mm
Armrest height:	200 - 300 mm
Front side armpad to front side backrest:	315 mm
Turning radius:	2300 mm
Testdummy weight:	150 kg
Maximum user weight:	150 kg
Control power:	1 N at hand control
Intended use:	Outdoor, Class C
User area:	European climate

* At average use in combination with dry batteries 73 Ah

The scooter further fulfills the following standards:

ISO 7176- 8: demands and testing methods for static, shock and fatigue strength

ISO 7176- 9: climate tests for scooters

ISO 7176-14: drive and control units for scooters

ISO 7176-16: demands for burn resistance

Other technical data

Battery space(lxbxh): (2x) 385x285x210 mm

Mass of batteries: ± 23 kg per piece (dry batteries 75 Ah/20)

Elektronic control: Rhino 110

Engines: 24 VDC, 230 Watt, 4000 rpm

Wheel size front: 4.00 - 5

Wheel size rear: 4.00 - 5

Tire pressure (front) : 50 PSI

Tire pressure (rear) : 50 PSI

Minimum battery capacity: 50Ah

EXCEL



EXCEL

VAN OS

For international customers:

VAN OS MEDICAL B.V.
Koperslagerij 9
4651 SK Steenberg
The Netherlands

Tel.: +31 (0) 167 573020
Fax: +31 (0) 167 573381
E-mail: sales@vanosmedical.nl

For UK and Ireland:

VAN OS MEDICAL UK LTD.
42-44 OuseGate
YO8 4NH Selby, United Kingdom

Tel.: +44 (0) 1757 701177
Fax: +44 (0) 1757 706011
E-mail: sales@vanosmedical.com

www.vanosmedical.com