

# COLT TWIN



OWNER'S MANUAL

**Pride**  
Mobility Products Ltd.  
[www.pridemobility.com](http://www.pridemobility.com)

32 Wedgwood Road Bicester, Oxon OX26 4UL

# SAFETY GUIDELINES



**WARNING!** An authorised Pride Dealer or qualified technician must perform the initial setup of this scooter and must perform all of the procedures in this manual.

The symbols below are used throughout this owner's manual and on the scooter to identify warnings and important information. It is very important for you to read them and understand them completely.



**WARNING!** Indicates a potentially hazardous condition/situation. Failure to follow designated procedures can cause either personal injury, component damage or malfunction. On the product, this icon is represented as a black symbol on a yellow triangle with a black border.



**MANDATORY!** These actions should be performed as specified. Failure to perform mandatory actions can cause personal injury and/or equipment damage. On the product, this icon is represented as a white symbol on a blue dot.



**PROHIBITED!** These actions are prohibited. These actions should not be performed at any time or in any circumstances. Performing a prohibited action can cause personal injury and/or equipment damage. On the product, this icon is represented as a black symbol with a red circle and a red slash.

Please fill out the following information for quick reference:

Pride Dealer:	_____
Address:	_____
Phone Number:	_____
Purchase Date:	_____
Serial Number:	_____

***NOTE: This owner's manual is compiled from the latest specifications and product information available at the time of publication. We reserve the right to make changes as they become necessary. Any changes to our products may cause slight variations between the illustrations and explanations in this manual and the product you have purchased. The latest/current version of this manual is available on our website.***

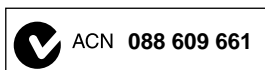

# CONTENTS

I. INTRODUCTION.....	4
II. SAFETY .....	5
III. YOUR SCOOTER .....	19
IV. BATTERIES AND CHARGING .....	24
V. OPERATION .....	31
VI. COMFORT ADJUSTMENTS.....	33
VII. DISASSEMBLY AND ASSEMBLY .....	36
VIII. BASIC TROUBLESHOOTING .....	38
IX. CARE AND MAINTENANCE .....	40
X. WARRANTY .....	43
APPENDIX I - SPECIFICATIONS .....	44

# I. INTRODUCTION

## SAFETY

Welcome to Pride Mobility Products Ltd. (Pride). The product you have purchased combines state-of-the-art components with **safety**, comfort and styling in mind. We are confident the design features will provide you with the conveniences you expect during your daily activities. Understanding how to **safely** operate and care for this product should bring you years of trouble free operation and service.

**Read and follow** all instructions, warnings and notes in this manual and all other accompanying literature before attempting to operate this product for the first time. In addition, your **safety** depends upon you, as well as your dealer, carer or healthcare professional in using good judgement.

If there is any information in this manual which you do not understand or if you require additional assistance for setup or operation, please contact your authorised Pride Dealer. **Failure to follow the instructions, warnings and notes in this manual and those located on your Pride product can result in personal injury or product damage and will void Pride's product warranty.**

## PURCHASER'S AGREEMENT

By accepting delivery of this product, you promise that you will not change, alter or modify this product or remove or render inoperable or unsafe any guards, shields or other safety features of this product; fail, refuse or neglect to install any retrofit kits from time to time provided by Pride to enhance or preserve the safe use of this product.

## SHIPPING AND DELIVERY

Before using your scooter, make sure your delivery is complete as some components may be individually packaged. If you do not receive a complete delivery, please contact your authorised Pride Dealer immediately. Where damage has occurred during transport, either to the packaging or content, please contact the delivery company responsible.

## INFORMATION EXCHANGE

We want to hear your questions, comments and suggestions about this manual. We would also like to hear about the safety and reliability of your new scooter and about the service you received from your authorised Pride Dealer. Please notify us of any change of address, so we can keep you apprised of important information about safety, new products and new options that can increase your ability to use and enjoy your scooter. Please feel free to contact us at the address below:

Pride Mobility Products Ltd.  
32 Wedgwood Road  
Bicester, Oxon OX26 4UL

***NOTE: If you ever lose or misplace your product registration card or your copy of this manual, contact us and we will be glad to send you a new one immediately.***

## II. SAFETY

### PRODUCT SAFETY SYMBOLS

The symbols below are used on the scooter to identify warnings, mandatory actions and prohibited actions. It is very important for you to read and understand them completely.



Pinch/Crush points created during assembly.



Corrosive chemicals contained in battery.



EMI-RFI- This product has been tested and passed at an immunity level of 20 V/m.



Do not lift the mobility vehicle while seated in it.



Do not lift the mobility vehicle while seated in it.



Explosive conditions exist!



Read and follow the information in the owner's manual.

## II. SAFETY



Maximum seating weight.



Do not place the scooter in freewheel mode on a decline or incline.

Unlocked and in freewheel mode.

Place unit on level ground and stand to one side when changing from drive mode to freewheel mode or freewheel mode to drive mode.

Locked and in drive mode.



Wear safety goggles.



Use only AGM or Gel-Cell batteries to reduce the risk of leakage or explosive conditions.



Do not raise or lower the power seat while the scooter is in motion.



Do not remove anti-tip wheels.

## II. SAFETY



Do not use a cell phone, walkie/talkie, laptop or other radio transmitter while operating.



Avoid exposure to rain, snow, ice, salt or standing water whenever possible. Maintain and store in a clean and dry condition.



Removal of grounding prong can create electrical hazard. If necessary, properly install an approved 3-pronged adapter to an electrical outlet having 2-pronged plug access.

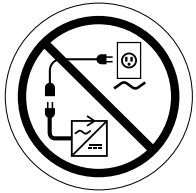

Do not connect an extension lead to the AC/DC converter or the battery charger.

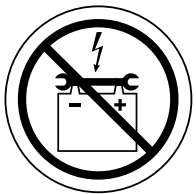

Keep tools and other metal objects away from battery terminals. Contact with tools can cause electrical shock.



Do not allow unsupervised children to play near the scooter while the batteries are charging.



Do not use batteries with different amp-hour (Ah) capacities. Do not mix old and new batteries. Always replace both batteries at the same time.

## II. SAFETY



Keep your hands away from the tyres when driving. Be aware that loose fitting clothing can become caught in drive tyres.



Battery charger for indoor use only.



Disposal and recycling - Contact your authorised Pride Dealer for information on proper disposal and recycling of your Pride product and its packaging.



Contains Lead.

# II. SAFETY

## GENERAL



**MANDATORY!** Do not operate your new scooter for the first time without completely reading and understanding this owner's manual.

Your scooter is a state-of-the-art life-enhancement device designed to increase mobility. Pride provides an extensive variety of products to best fit the individual needs of the scooter user. Please be aware that the final selection and purchasing decision regarding the type of scooter to be used is the responsibility of the scooter user, who is capable of making such a decision and his/her healthcare professional (i.e., medical doctor, physical therapist, etc.).

The contents of this manual are based on the expectation that a mobility device expert has properly fitted the scooter to the user and has assisted the prescribing healthcare professional and/or the authorised Pride Dealer in the instruction process for the use of the product.

There are certain situations, including some medical conditions, where the scooter user will need to practice operating the scooter in the presence of a trained attendant. A trained attendant can be defined as a family member or care professional specially trained in assisting a scooter user in various daily living activities.

As you begin using your scooter during daily activities, you will probably encounter situations in which you will need some practice. Simply take your time and you will soon be in full and confident control as you maneuver through doorways, on and off lifts, up and down ramps and over moderate terrain.

Below are some precautions, tips and other safety considerations that will help you become accustomed to operating the scooter safely.

## MODIFICATIONS

Pride has designed and engineered your scooter to provide maximum mobility and utility. However, under no circumstances should you modify, add, remove or disable any feature, part or function of your scooter.



**WARNING!** Do not modify your scooter in any way not authorised by Pride. Do not use accessories if they have not been tested or approved for Pride products.

## REMOVABLE PARTS



**WARNING!** Do not attempt to lift or move your scooter by any of its removable parts, including the armrests, seat or shroud.

## PRE-RIDE SAFETY CHECK

Get to know the feel of your scooter and its capabilities. Pride recommends that you perform a safety check before each use to make sure your scooter operates smoothly and safely.

## II. SAFETY

### Perform the following inspections prior to using your scooter:

- Check for proper tyre inflation. Maintain but do not exceed the psi/bar/kPa air pressure rating indicated on each tyre if equipped with pneumatic tyres.
- Check all electrical connections. Make sure they are tight and not corroded.
- Check all harness connections. Make sure they are secured properly.
- Check the brakes.
- Check battery charge.

If you discover a problem, contact your authorised Pride Dealer for assistance.

### TYRE INFLATION

If your scooter is equipped with pneumatic tyres, you should check or have the air pressure checked at least once a week. Proper inflation pressures will prolong the life of your tyres and help ensure the smooth operation of your scooter.



WARNING! It is critically important that the psi/bar/kPa air pressure rating indicated on the tyre be maintained in pneumatic tyres at all times. Do not underinflate or overinflate your tyres. Low pressure may result in loss of control and overinflated tyres may burst. Failure to maintain the psi/bar/kPa air pressure rating indicated on the pneumatic tyres at all times may result in tyre and/or wheel failure.

WARNING! Inflate your scooter tyres from a regulated air source with an available pressure gauge. Inflating your tyres from an unregulated air source could overinflate them, resulting in a burst tyre.

**NOTE:** *If the tyres on your scooter list the psi rating only, use the following conversion formulas to find the bar or kPa rating:  $bar = psi \times 0.06895$ ;  $kPa = psi \times 6.89476$ .*

### WEIGHT LIMITATIONS

Your scooter is rated for a maximum weight capacity. Refer to the specifications table for information.



MANDATORY! Stay within the specified weight capacity for your scooter. Exceeding the weight capacity voids your warranty. Pride will not be held responsible for injuries and/or property damage resulting from failure to observe weight limitations.



WARNING! Do not carry passengers on your scooter. Carrying passengers on your scooter may affect the centre of gravity, resulting in a tip or a fall.

### INCLINE INFORMATION

More and more buildings have ramps with specified degrees of inclination, designed for easy and safe access. Some ramps may have turning switchbacks (180-degree turns) that require you to have good cornering skills on your scooter.

- Proceed with extreme caution as you approach the downgrade of a ramp or other incline.
- Take wide swings with your scooter around any tight corners. If you do that, the scooter's rear wheels will follow a wide arc, not cut the corner short and not bump into or get hung up on any railing corners.
- When driving down a ramp, keep the scooter's speed adjustment set to the slowest speed setting to ensure a safely controlled descent.
- Avoid sudden stops and starts.

## II. SAFETY

When climbing an incline, try to keep your scooter moving. If you must stop, start up again slowly and then accelerate cautiously. When driving down an incline, do so by setting the speed adjustment dial to the slowest setting and driving in the forward direction only. If your scooter starts to move down the incline faster than you anticipated or desired, allow it to come to a complete stop by releasing the throttle control lever. Then push the throttle control lever forward slightly to ensure a safely controlled descent.



WARNING! When on any sort of an incline or decline, never place the scooter in freewheel mode, especially when seated on it or standing next to it.

WARNING! When climbing an incline, do not zigzag or drive at an angle up the face of the incline. Drive your scooter straight up the incline. This greatly reduces the possibility of a tip or a fall. Always exercise extreme caution when negotiating an incline.



WARNING! Do not drive your scooter across the side of an incline or diagonally up or down an incline; do not stop, if possible, while driving up or down an incline.

WARNING! You should not travel up or down a potentially hazardous incline (i.e., areas covered with snow, ice, cut grass or wet leaves).

WARNING! Even though your scooter is capable of climbing slopes greater than those illustrated in figure 1, do not, under any circumstances, exceed the incline guidelines or any other specifications presented in this manual. Doing so could cause instability in your scooter.

Handicap public access ramps are not subject to government regulation in all countries and therefore do not necessarily share the same standard percent of slope. Other inclines may be natural or, if man-made, not designed specifically for scooters. **Figure 1** illustrates your scooter's stability and its ability to climb grades under various weight loads and under controlled testing conditions.

These tests were conducted with the scooter's seat in the highest position and adjusted rearward on the seat base to its farthest rearward position. Use this information as a guideline. Your scooter's ability to travel up inclines is affected by your weight, your scooter's speed, your angle of approach to the incline and your scooter setup.



WARNING! Any attempt to climb or descend a slope steeper than what is shown in figure 1 may put your scooter in an unstable position and cause it to tip.

WARNING! Never carry an oxygen tank weighing more than 15 lbs. (6.8 kg). Never fill the front or rear basket with contents exceeding 15 lbs. (6.8 kg).

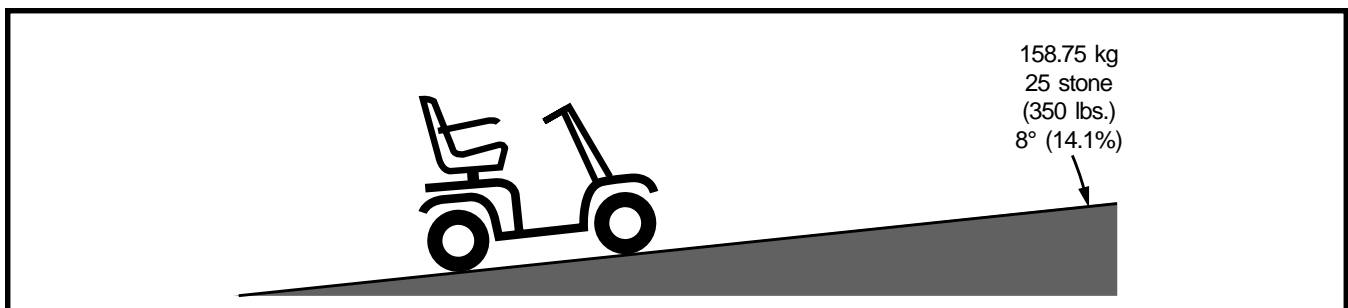

Figure 1. Maximum Recommended Incline Angle

## II. SAFETY

When you approach an incline, it is best to lean forward. See figures 2 and 2A. This shifts the centre of gravity of you and your scooter toward the front of the scooter for improved stability.

**NOTE:** When negotiating ramps, if the throttle control lever is released while moving forward, the powered scooter may "roll back" approximately 1 foot (30.48 cm) before the brake engages. If the throttle control lever is released while moving in reverse, the powered scooter may "roll back" approximately 3 feet (1 meter) before the brake engages.

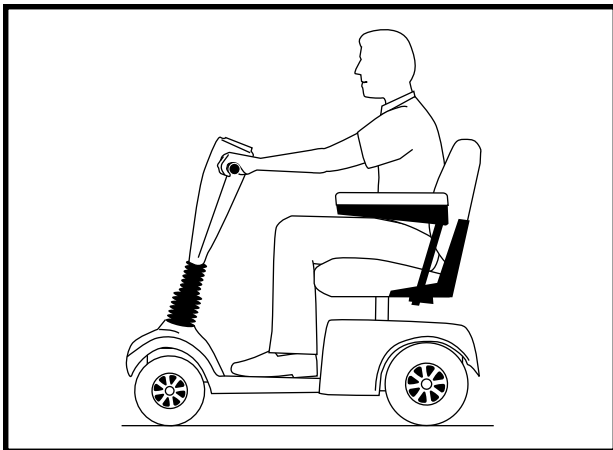

Figure 2. Normal Driving Position

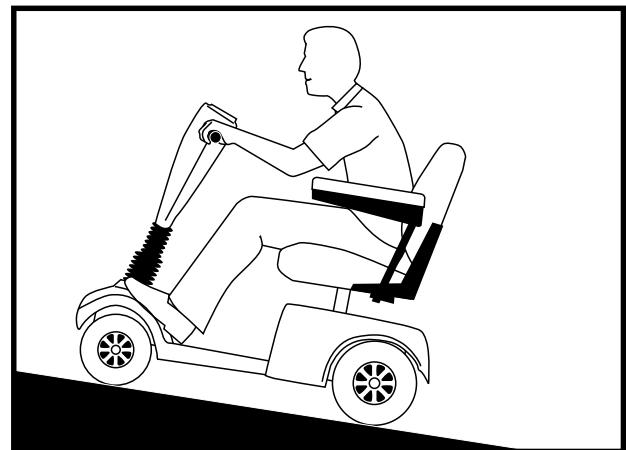

Figure 2A. Increased Stability Driving Position

### CORNERING INFORMATION

Excessively high cornering speeds can create the possibility of tipping. Factors which affect the possibility of tipping include, but are not limited to, cornering speed, steering angle (how sharply you are turning), uneven road surfaces, inclined road surfaces, riding from an area of low traction to an area of high traction (such as passing from a grassy area to a paved area – especially at high speed while turning) and abrupt directional changes. High cornering speeds are not recommended. If you feel that you may tip over in a corner, reduce your speed and steering angle (i.e., lessen the sharpness of the turn) to prevent your scooter from tipping.



**WARNING!** When cornering sharply, reduce your speed and maintain a stable centre of gravity. When using your scooter at higher speeds, do not corner sharply. This greatly reduces the possibility of a tip or fall. Always exercise common sense when cornering.

### BRAKING INFORMATION

Your scooter is equipped with these powerful brake systems:

- **Regenerative:** Uses electricity to rapidly slow the vehicle when the throttle control lever returns to the centre/stop position.
- **Disc Park Brake:** Activates mechanically after regenerative braking slows the vehicle to near stop or when power is removed from the system for any reason.

## II. SAFETY

### OUTDOOR DRIVING SURFACES

Your scooter is designed to provide optimum stability under normal driving conditions—dry, level surfaces composed of concrete, blacktop or tarmac. However, Pride recognizes that there will be times when you will encounter other surface types. For this reason, your scooter is designed to perform admirably on packed soil, grass and gravel. Feel free to use your scooter safely on lawns and in park areas.

- Reduce your scooter's speed when driving on uneven terrain and/or soft surfaces.
- Avoid tall grass that can become tangled in the running gear.
- Avoid loosely packed gravel and sand.
- If you feel unsure about a driving surface, avoid that surface.

### PUBLIC STREETS AND ROADWAYS



WARNING! Exercise extreme caution when operating the Travel Scooter on footpaths, pavements, bridleways, pedestrian areas and roads. Obey all local pedestrian traffic rules.

### STATIONARY OBSTACLES (STEPS, KERBS, ETC.)

WARNING! Do not drive near raised surfaces, unprotected ledges and/or drop-offs (kerbs, porches, stairs, etc.).

WARNING! Do not attempt to have your scooter climb or descend an obstacle that is inordinately high.



WARNING! Do not attempt to have your scooter proceed backward down any step, kerb or other obstacle. This may cause the scooter to tip.

WARNING! Be sure your scooter is traveling perpendicular to any kerb you may be required to ascend or descend. See figures 3 and 3A.

WARNING! Do not attempt to negotiate a kerb that has a height greater than 2 in. (5 cm).

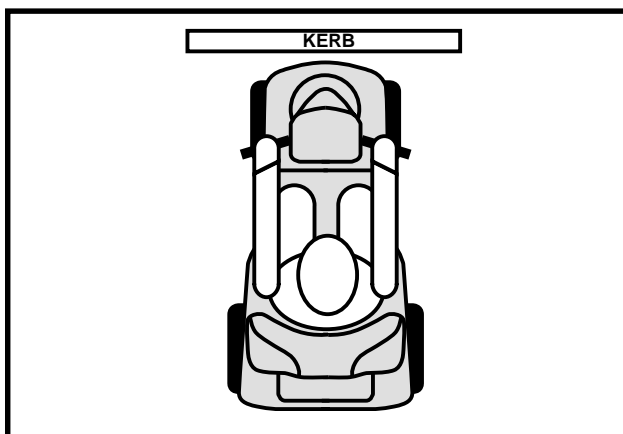

Figure 3. Correct Kerb Approach

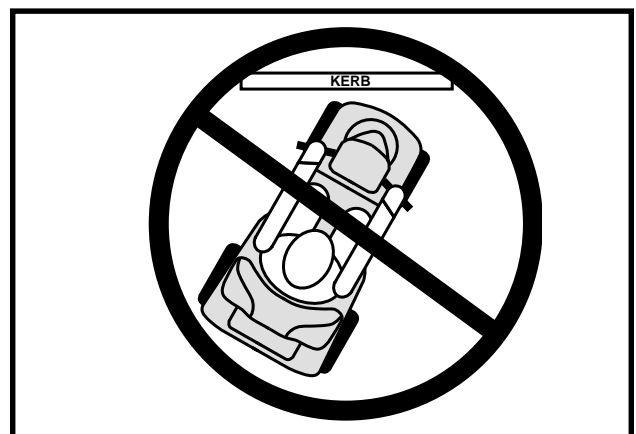

Figure 3A. Incorrect Kerb Approach

## II. SAFETY

### INCLEMENT WEATHER PRECAUTIONS

Exposure of your scooter to inclement weather conditions should be avoided whenever possible. If suddenly caught up in rain, snow, severe cold or heat while operating your scooter, proceed to shelter at the earliest opportunity. Thoroughly dry your scooter before storing, charging or operating your scooter.



**PROHIBITED!** Operating in rain, snow, salt, mist/spray conditions and on icy/slippery surfaces can cause damage to the scooter and electrical system. Maintain and store your scooter in a dry and clean condition.



**WARNING!** Prolonged exposure to hot or cold conditions may affect the temperature of upholstered and non-upholstered items on the scooter, possibly resulting in skin irritation. Exercise caution when using your scooter in extremely hot or cold conditions or when exposing your scooter to direct sunlight for prolonged periods of time.

### FREEWHEEL MODE

Your scooter is equipped with a manual freewheel lever that, when engaged, allows the scooter to be pushed. For more information about how to place your scooter into and out of freewheel mode, see III. “Your Scooter.”



**WARNING!** When your scooter is in freewheel mode, the braking system is disengaged.

- Disengage the drive motors only on a level surface.
- Ensure the key is removed from the key switch.
- Stand to the side of the scooter to engage or disengage freewheel mode. Never sit on a scooter to do this.
- After you have finished pushing your scooter, always return it to the drive mode to lock the brakes.

An added feature built into the scooter is “**push-too-fast**” protection which safeguards the scooter against gaining excessive speed while in freewheel mode.

“Push-too-fast” operates differently depending on which of two conditions exists:

- If the key is switched “off” while in freewheel mode, the scooter’s controller activates regenerative braking when the scooter is pushed faster than a maximum threshold which has been preprogrammed. In this case, the controller is acting as a speed governor.
- If the key is switched “on” while in freewheel mode, you will encounter considerable resistance at any speed. This prevents the scooter from gaining unwanted momentum should the manual freewheel lever inadvertently be released while driving the scooter.

### STAIRS AND ESCALATORS

Scooters are not designed to travel up or down stairs or escalators. Always use an lift.



**WARNING!** Do not use your scooter to negotiate steps or escalators.

## II. SAFETY

### DOORS

- Determine if the door opens toward or away from you.
- Use your hand to turn the knob or push the handle or push-bar.
- Drive your scooter gently and slowly forward to push the door open. Or drive your scooter gently and slowly backwards to pull the door open.

### LIFTS

Modern lifts have a door edge safety mechanism that, when pushed, reopens the door(s).

- If you are in the doorway of a lift when the door(s) begin to close, push on the rubber door edge or allow the rubber door edge to contact the scooter and the door will reopen.
- Use care that pocketbooks, packages or scooter accessories do not become caught in lift doors.

**NOTE: If your scooter's turning radius is greater than 60 in. (152.4 cm), it may be difficult to maneuver in lifts and building entrances. Use caution when attempting to turn or maneuver your scooter in small spaces and avoid areas that might pose a problem.**

### LIFT/ELEVATION PRODUCTS

If you will be traveling with your scooter, you may find it necessary to use a lift/elevation product to aid in transportation. Pride recommends that you closely review the instructions, specifications and safety information set forth by the manufacturer of the lift/elevation product before using that product.



**WARNING!** Never sit on your scooter when it is being used in connection with any type of lift/elevation product. Your scooter was not designed with such use in mind and any damage or injury incurred from such use is not the responsibility of Pride.

### BATTERIES

In addition to following the warnings below, be sure to comply with all other battery handling information.



**MANDATORY!** Battery posts, terminals and related accessories contain lead and lead compounds. Wear goggles and gloves when handling batteries and wash hands after handling.

**WARNING!** Scooter batteries are heavy. See specifications table. If you are unable to lift that much weight, be sure to get help. Use proper lifting techniques and avoid lifting beyond your capacity.



**WARNING!** Always protect the batteries from freezing and never charge a frozen battery. Charging a frozen battery may result in damage to the battery.

**WARNING!** Connect the battery harnesses in the proper manner. RED (+) cables must be connected to positive (+) battery terminals/posts. BLACK (-) cables must be connected to negative (-) battery terminals/posts. Protective caps should be installed over all battery terminals. REPLACE cables immediately if damaged.

## II. SAFETY

### BATTERY DISPOSAL AND RECYCLING

If you encounter a damaged or cracked battery, immediately enclose it in a plastic bag. Contact your local waste disposal agency or your authorised Pride Dealer for instructions on disposal and battery recycling, which is our recommended course of action.

### PREVENTING UNINTENDED MOVEMENT



WARNING! If you anticipate being seated in a stationary position for an extended period of time, turn off the power. This will prevent unexpected motion from inadvertent throttle control lever contact.

### MOTOR VEHICLE TRANSPORT

Pride recommends that you do not remain seated in your scooter while traveling in a motor vehicle. The scooter should be stowed in the boot of a car or in the back of a truck or van with batteries removed and properly secured. In addition, all removable scooter parts, including the armrests, seat and shroud should be removed and/or properly secured during motor vehicle transport. In addition, all removable scooter parts, including the armrests, seat and shroud should be removed and/or properly secured during motor vehicle transport.

WARNING! Although your scooter may be equipped with a positioning belt, this belt is not designed to provide proper restraint during motor vehicle transport. Anyone traveling in a motor vehicle should be properly secured in the motor vehicle seat with safety belts fastened securely.



WARNING! Do not sit on your scooter while it is in a moving vehicle.

WARNING! Always be sure your scooter and its batteries are properly secured when it is being transported. Batteries should be secured in an upright position and protective caps should be installed on the battery terminals. Batteries should not be transported with any flammable or combustible items.

### GETTING ONTO AND OFF OF YOUR SCOOTER

Getting onto and off of your scooter requires a good sense of balance. Please observe the following safety tips when getting onto and off of your scooter:

- Remove the key from the key switch.
- Ensure that your scooter is not in freewheel mode. See III. “Your Scooter.”
- Make certain that the seat is secured into place.
- Pivot the armrests up to make getting onto and off of the scooter easier.

WARNING! Position yourself as far back as possible in the scooter seat to prevent the scooter from tipping.



WARNING! Avoid putting all of your weight on the scooter armrests and do not use the armrests for weight bearing purposes, such as transfers. Such use may cause the scooter to tip, resulting in a fall from the scooter and personal injury.

WARNING! Avoid putting all of your weight on the floorboard. Such use may cause the scooter to tip.

## II. SAFETY

### REACHING AND BENDING

Avoid reaching or bending while driving your scooter. Bending forward creates the risk of accidental throttle control lever contact. Bending to the side while seated creates the risk of tipping. It is important to maintain a stable centre of gravity and keep the scooter from tipping. Pride recommends that the scooter user determine his/her personal limitations and practice bending and reaching in the presence of a qualified attendant.



**WARNING!** Do not bend, lean or reach for objects if you have to pick them up from the scooter deck or from either side of the scooter. Movements such as these may change your centre of gravity and the weight distribution of the scooter and cause your scooter to tip.



**PROHIBITED!** Keep your hands away from the tyres when driving. Be aware that loose fitting clothing can become caught in drive tyres.

### POSITIONING BELTS

Your authorised Pride Dealer, therapist(s) and other healthcare professionals are responsible for determining your requirement for a positioning belt in order to operate your scooter safely.



**WARNING!** If you require a positioning belt to safely operate your scooter, make sure it is fastened securely.

### PRESCRIPTION DRUGS/PHYSICAL LIMITATIONS

The scooter user must exercise care and common sense when operating his/her scooter. This includes awareness of safety issues when taking prescribed or over-the-counter drugs or when the user has specific physical limitations.



**WARNING!** Consult your physician if you are taking prescribed or over-the-counter medication or if you have certain physical limitations. Some medications and limitations may impair your ability to operate your scooter in a safe manner.

### ALCOHOL/SMOKING

The scooter user must exercise care and common sense when operating his/her scooter. This includes awareness of safety issues while under the influence of alcohol or while smoking.

**WARNING!** Do not operate your scooter while you are under the influence of alcohol, as this may impair your ability to drive safely.



**WARNING!** Pride strongly recommends that you do not smoke cigarettes while seated in your scooter, although the scooter has passed the necessary testing requirements for cigarette smoking. You must adhere to the following safety guidelines if you decide to smoke cigarettes while seated in your scooter.

- Do not leave lit cigarettes unattended.
- Keep ashtrays a safe distance from the seat cushions.
- Always make sure cigarettes are completely extinguished before disposal.

## II. SAFETY

### ELECTROMAGNETIC AND RADIO FREQUENCY INTERFERENCE (EMI/RFI)



WARNING! Laboratory tests have shown that electromagnetic and radio frequency waves can have an adverse affect on the performance of electrically-powered mobility vehicles.

Electromagnetic and Radio Frequency Interference can come from sources such as cellular phones, mobile two-way radios (such as walkie-talkies), radio stations, TV stations, amateur radio (HAM) transmitters, wireless computer links, microwave signals, paging transmitters and medium-range mobile transceivers used by emergency vehicles. In some cases, these waves can cause unintended movement or damage to the control system. Every electrically-powered mobility vehicle has an immunity (or resistance) to EMI. The higher the immunity level, the greater the protection against EMI. This product has been tested and has passed at an immunity level of 20 V/M.



WARNING! Be aware that cell phones, two-way radios, laptops and other types of radio transmitters may cause unintended movement of your electrically-powered mobility vehicle due to EMI. Exercise caution when using any of these items while operating your mobility vehicle and avoid coming into close proximity of radio and TV stations.



WARNING! The addition of accessories or components to the electrically-powered mobility vehicle can increase the susceptibility of the vehicle to EMI. Do not modify your scooter in any way not authorised by Pride.

WARNING! The electrically-powered mobility vehicle itself can disturb the performance of other electrical devices located nearby, such as alarm systems.

***NOTE: For further information on EMI/RFI, visit the Resource Center on [www.pridemobility.com](http://www.pridemobility.com). If unintended motion or brake release occurs, turn your scooter off as soon as it is safe to do so. Contact your authorised Pride Dealer to report the incident.***

# III. YOUR SCOOTER

## TILLER CONSOLE

The tiller console houses all of the controls needed to drive your scooter, including the speed adjustment dial, key switch, battery condition meter, status LED, horn buttons, turn indicator buttons, accessory switches and the throttle control lever. See figure 4.



**PROHIBITED!** Do not expose the tiller console to moisture. In the event that the tiller console does become exposed to moisture, do not attempt to operate your scooter until the tiller console has dried thoroughly.

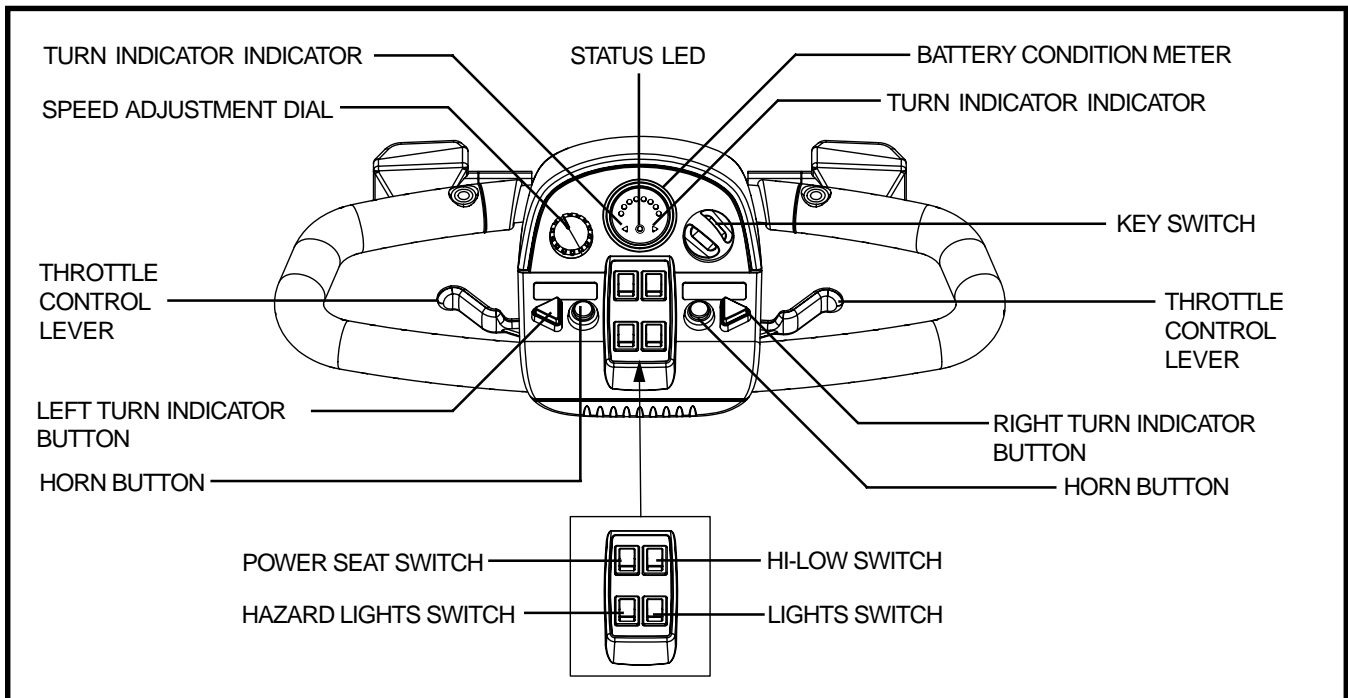

Figure 4. Tiller Console Components

### Speed Adjustment Dial

This dial allows you to preselect and limit your scooter's top speed.

- The image of the tortoise represents the slowest speed setting.
- The image of the hare represents the fastest speed setting.

### Key Switch

- Insert the key into the key switch and turn it clockwise to power up (turn on) your scooter.
- Turn the key anticlockwise to power down (turn off) your scooter.



**WARNING!** If the key is turned to the "off" position while your scooter is in motion, the electronic brakes will engage and your scooter will come to an abrupt stop!

### Battery Condition Meter

When the key is fully inserted and turned clockwise to power up your scooter, this meter indicates the approximate battery voltage strength. For further information on battery charging, see IV. "Batteries and Charging."

# III. YOUR SCOOTER

## Status LED

The status LED alerts you to electrical problems that may occur with the scooter. The LED remains constantly lit while your scooter is on. If your scooter develops an electrical problem, the status LED will flash a code. See VIII. “Basic Troubleshooting” for flash codes.

## Horn Buttons

These buttons activate a warning horn. Your scooter must be powered up for the horn to be operational. Do not hesitate to use the warning horn when doing so may prevent accident or injury.

## Turn indicator Buttons

Use these buttons to turn on the left and right turn indicator (amber) lights.

- Push the left button to activate the left turn indicator light. The turn indicator LED located in the battery condition meter will flash.
- Push the right button to activate the right turn indicator light. The turn indicator LED located in the battery condition meter will flash.
- The turn indicators are timed to shut off automatically.

## Lights Switch

This switch controls your scooter’s lighting system.

- Toggle the switch forward to turn on the front lower light.
- Toggle the switch rearward to turn off the front lower light.



WARNING! Scooter users are required to use their lights when visibility is restricted—day or night.

## Hazard Lights Switch

This switch activates the 4-way flashers on your scooter.

- Toggle the hazard lights switch forward to turn on the flashers.
- Toggle the hazard lights switch rearward to turn off the flashers.

## Hi-Low Switch

This switch toggles the scooter’s speed between HI and LOW.

- Toggle the switch forward (HI) and your scooter’s maximum speed is 5.25 mph (8.45 km/h).
- Toggle the switch rearward (LOW) and your scooter’s maximum speed is 2.625 mph (4.22 km/h).

## Power Seat Switch

The power seat switch activates the power seat actuator and enables you to raise and lower the seat automatically. Refer to VI. “Comfort Adjustments” for more information regarding power seat operation and safety.

# III. YOUR SCOOTER

## Throttle Control Lever

This lever allows you to control the forward speed and the reverse speed of your scooter up to the maximum speed you preset with the speed adjustment dial.

### To Move Forward, use either of the following:

- Use your left thumb to push the left side of the throttle control lever.
- Use your right hand fingers to pull back on the right side of the throttle control lever.

### To Move Rearward, use either of the following:

- Use your right thumb to push the right side of the throttle control lever.
- Use your left hand fingers to pull back on the left side of the throttle control lever.

Release the throttle control lever and allow your scooter to come to a complete stop before engaging the other side of the lever. When the throttle control lever is completely released, it automatically returns to the centre “stop” position and engages your scooter’s brakes.

## Off-board Charger Port

The off-board charger power lead plugs into this port during battery charging. The off-board charger port will be located on the tiller or on the right battery box depending on which scooter model you own. See figures 5 and 5A.

## Electrical System Fuses

Your scooter is equipped with a series of electrical system fuses, which help protect the off-board charging system, key switch and lighting system from receiving an overload of electrical current. These fuses are the same type used in automobiles and are located in a compartment on the tiller. See figure 6. If your scooter is equipped with battery boxes, a separate 10-amp fuse is located on the right battery box. See figure 5A. This fuse protects the off-board charging system when the batteries are charged off of the scooter. See IX. “Care and Maintenance” for fuse replacement.

**NOTE:** Keep all electrical areas clean and free of moisture and foreign material.

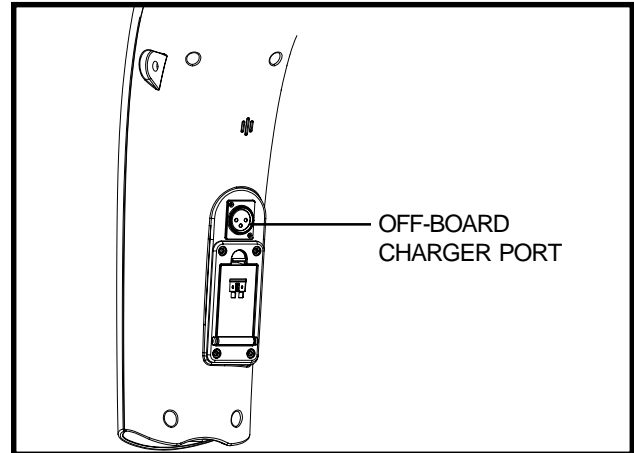

Figure 5. Off-board Charger Port (Tiller Mounted)

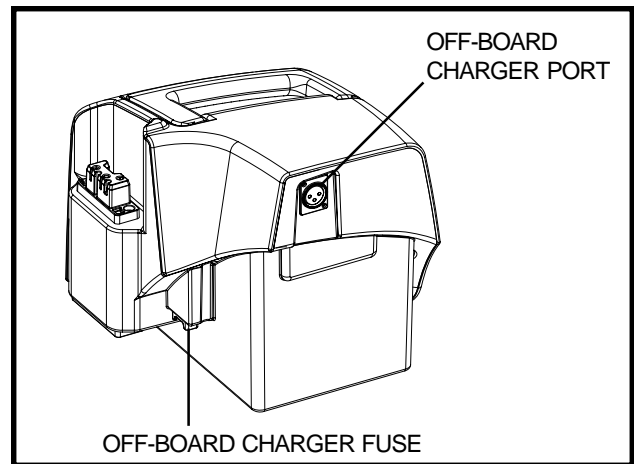

Figure 5A. Off-board Charger Port (Battery Box Mounted)

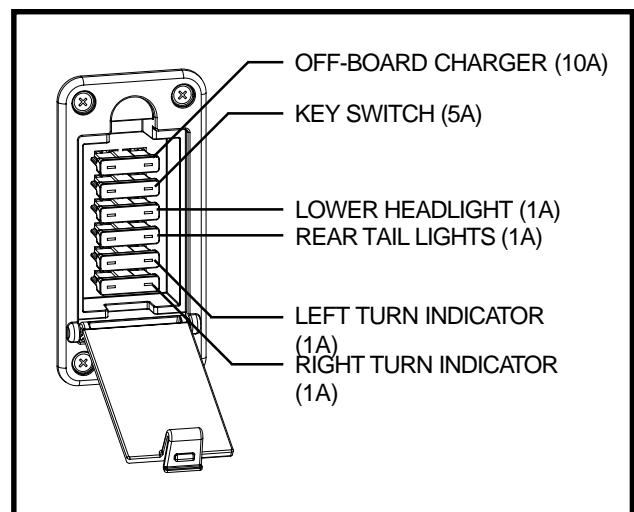

Figure 6. Tiller Console Fuses

# III. YOUR SCOOTER

## REAR SECTION

The batteries, anti-tip wheels, motor/transaxle assembly, main circuit breaker (reset button) and the manual free-wheel lever are located on the rear section of your scooter. See figure 7.

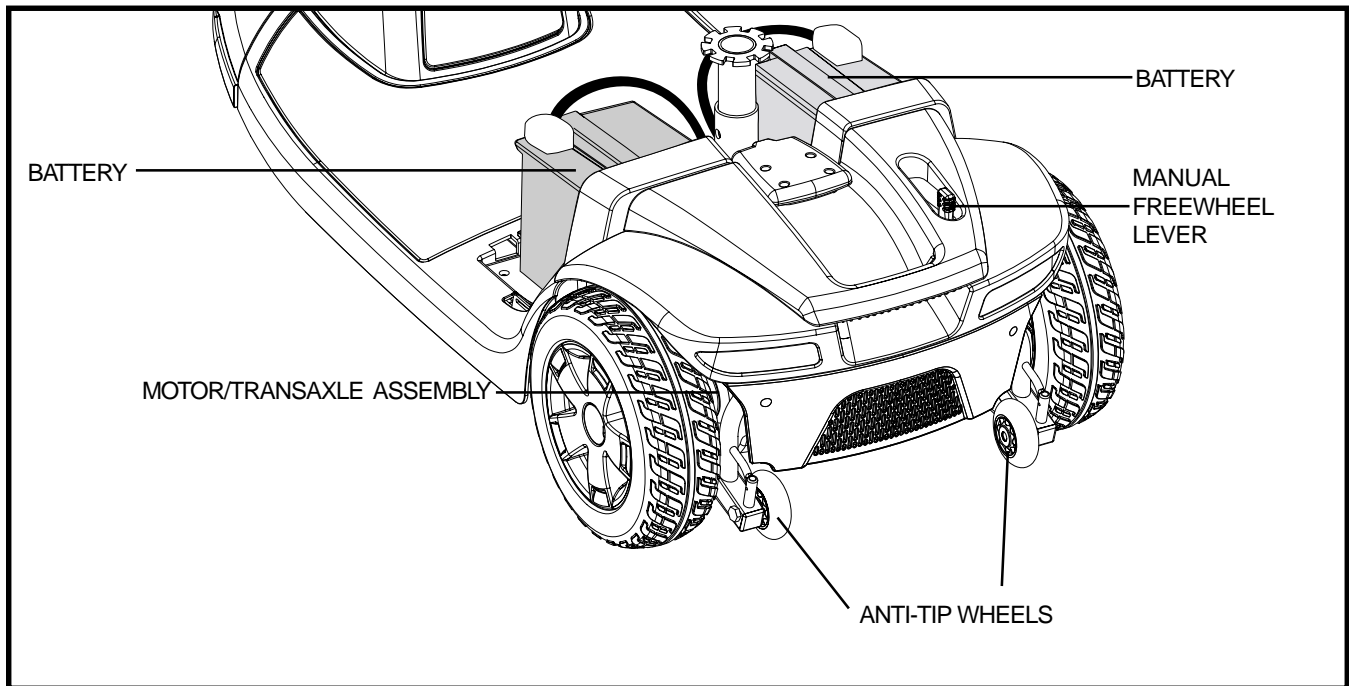

Figure 7. Rear Section

### Batteries

The batteries store electrical energy that powers your scooter. See IV. “Batteries and Charging” for information on how to charge your scooter batteries.

### Anti-Tip Wheels

The anti-tip wheels are an integral and important safety feature of your scooter. They are bolted to the frame at the rear of the scooter.



**PROHIBITED!** Do not remove the anti-tip wheels or modify your scooter in any way that is not authorised by Pride.

### Motor/Transaxle Assembly

The motor/transaxle assembly is an electromechanical unit that converts electrical energy from your scooter’s batteries into the controlled mechanical energy that drives the scooter’s wheels.

# III. YOUR SCOOTER

## Main Circuit Breaker (Reset Button)

When the voltage in the batteries becomes low or your scooter is heavily strained because of excessive loads, the main circuit breaker may trip to protect the motor and electronics from damage. When the breaker trips, the entire electrical system shuts down. **See figures 8 and 8A.**

- The reset button pops out when the breaker trips.
- Allow a minute or so for the electronics to “rest.”
- Push in the reset button to reset the breaker.
- If the breaker trips frequently, you may need to charge the batteries more often or have your authorised Pride Dealer perform a load test on the batteries.
- If the main circuit breaker trips repeatedly, see your authorised Pride Dealer for service.

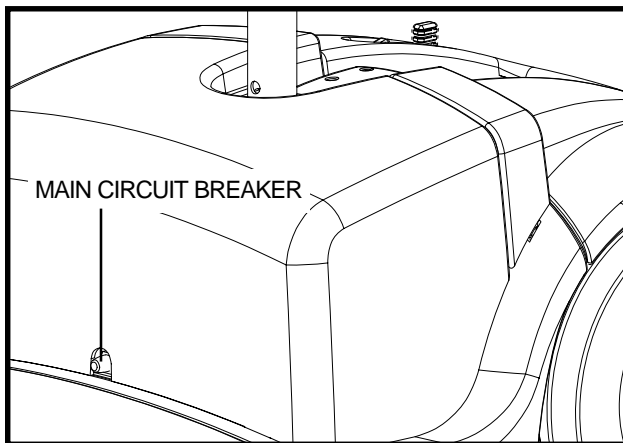

Figure 8. Main Circuit Breaker (Rear Section Mounted)

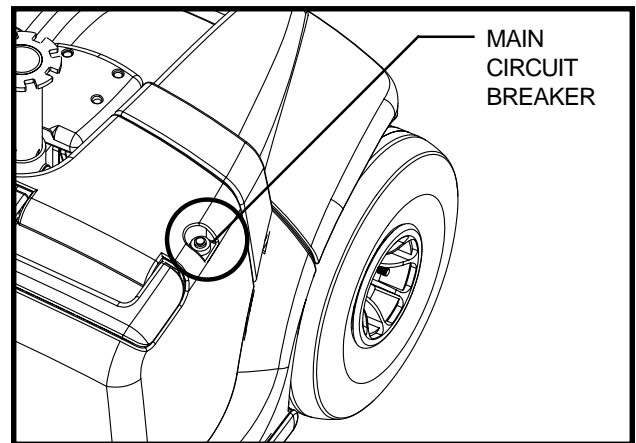

Figure 8A. Main Circuit Breaker (Battery Box Mounted)

## Manual Freewheel Lever

Whenever you need or want to push your scooter for short distances, you can put it in freewheel mode.

1. Remove the key from the key switch.
2. Push forward on the manual freewheel lever to disable the drive system and the brake system. This will enable you to push the scooter.
3. Pull back on the manual freewheel lever to reengage the drive and the brake systems and take your scooter out of freewheel mode.



**WARNING!** When your scooter is in freewheel mode, the braking system is disengaged.

- Disengage the drive motors only on a level surface.
- Ensure the key is removed from the key switch.
- Stand to the side of the scooter to engage or disengage freewheel mode. Never sit on a scooter to do this.
- After you have finished pushing your scooter, always return it to the drive mode to lock the brakes.

**NOTE:** *If the scooter is placed in freewheel mode (manual freewheel lever forward) while the key is in the “on” position, the scooter will not run until the manual freewheel lever is pushed backward and the key is turned to the “off” position, then back to the “on” position.*

# IV. BATTERIES AND CHARGING

## BATTERIES AND CHARGING

Your scooter requires two long-lasting, 12-volt, deep-cycle batteries that are sealed and maintenance free. They are recharged by an off-board charging system.

- Charge your scooter's batteries prior to using it for the first time.
- Keep the batteries fully charged to keep your scooter running smoothly.

## READING YOUR BATTERY VOLTAGE

The battery condition meter on the tiller console indicates the approximate strength of your batteries using a colour code. From right to left, green indicates fully charged batteries, yellow indicates a draining charge and red indicates that an immediate recharge is necessary. **See figure 9.** To ensure the highest accuracy, the battery condition meter should be checked while operating your scooter at full speed on a dry, level surface.

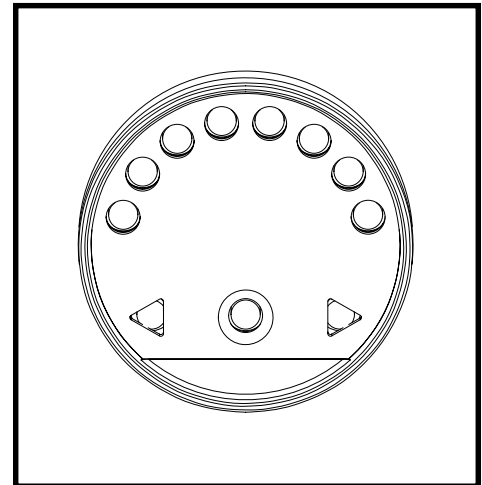

Figure 9. Battery Condition Meter

## CHARGING YOUR BATTERIES



**PROHIBITED!** Removal of grounding prong can create electrical hazard. If necessary, properly install an approved 3-pronged adapter to an electrical outlet having 2-pronged plug access.



**PROHIBITED!** Never use an extension lead to plug in your battery charger. Plug the charger directly into a properly wired standard electrical outlet.



**PROHIBITED!** Do not allow unsupervised children to play near the scooter while the batteries are charging. Pride recommends that you do not charge the batteries while the scooter is occupied.



**MANDATORY!** Read the battery charging instructions in this manual and in the manual supplied with the battery charger before charging the batteries.



**WARNING!** Explosive gases may be generated while charging the batteries. Keep the scooter and battery charger away from sources of ignition such as flames or sparks and provide adequate ventilation when charging the batteries.

**WARNING!** You must recharge your scooter's batteries with the supplied off-board charger. Do not use an automotive-type battery charger.



**WARNING!** Inspect the battery charger, wiring and connectors for damage before each use. Contact your authorised Pride Dealer if damage is found.

**WARNING!** Do not attempt to open the battery charger case. If the battery charger does not appear to be working correctly, contact your authorised Pride Dealer.

**WARNING!** If the battery charger is equipped with cooling slots, then do not attempt to insert objects through these slots.



**WARNING!** If your battery charger has not been tested and approved for outdoor use, then do not expose it to adverse or extreme weather conditions. If the battery charger is exposed to adverse or extreme weather conditions, then it must be allowed to adjust to the difference in environmental conditions before use indoors. Refer to the manual supplied with the battery charger for more information.

## IV. BATTERIES AND CHARGING

The off-board charger supplied with your scooter is equipped with a 115/230 voltage switch. Confirm that this switch is in the proper position for your locality. If you are not sure what the voltage is in your country, contact your local electricity provider before inserting the charger power lead plug into your electrical outlet. If the setting is incorrect, the charger will not function properly. Slide the voltage switch to the appropriate position. **See figure 10.**

The LED lights on the charger indicate different charger conditions at various times: charger power on, charging in progress, charging complete. Refer to the label on the charger for a complete explanation of these indicators.

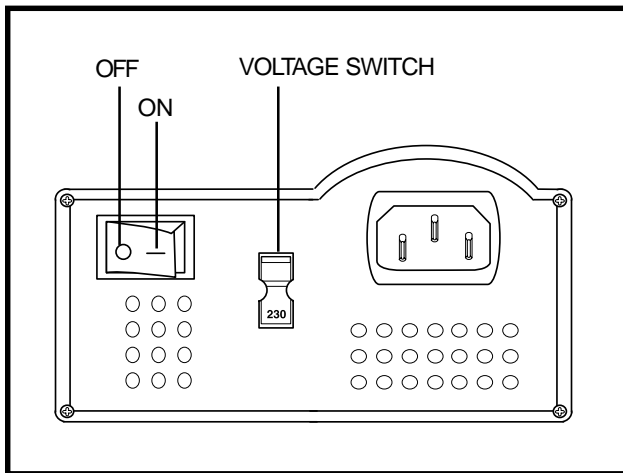

Figure 10. Charger On/Off and Voltage Switches

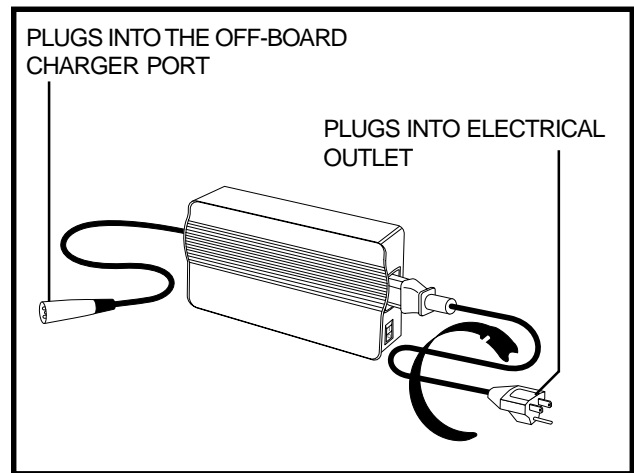

Figure 10A. Off-Board Charger

### If the off-board charger port is located on the tiller:

1. Position the front of your scooter close to a standard electrical outlet.
2. Remove the key from the key switch.
3. Make sure that the manual freewheel lever is in the drive position.
4. Make sure that the charger's on/off switch is in the OFF position. **See figure 10.**
5. Plug the 3-pin charger power lead into the off-board charger port. **See figures 5 and 10A.**
6. Extend the charger power lead and plug it into the electrical outlet.
7. Turn the charger on. We recommend that you charge the batteries for 8 to 14 hours.
8. When the batteries are fully charged, turn the charger off and unplug the charger power lead from the electrical outlet and then from the off-board charger port.

### If the off-board charger port is located on the battery box:

1. Position the rear of your scooter close to a standard electrical outlet.
2. Remove the key from the key switch.
3. Make sure that the manual freewheel lever is in the drive position.
4. Make sure that the charger's on/off switch is in the OFF position. **See figure 10.**
5. Plug the 3-pin charger power lead into the off-board charger port on the right battery box. **See figures 5A and 10A.**
6. Extend the charger power lead and plug it into the electrical outlet.
7. Turn the charger on. We recommend that you charge the batteries for 8 to 14 hours.
8. When the batteries are fully charged, turn the charger off and unplug the charger power lead from the electrical outlet and then from the off-board charger port.

## IV. BATTERIES AND CHARGING

**To charge the batteries with the battery boxes removed from the scooter:**

1. Remove the battery boxes from the scooter and place them on a flat, dry surface in exactly the same positions as they are on the scooter. **See figure 10B.** Refer to VII. “Disassembly and Assembly” for information on how to remove and position the battery boxes.

**NOTE: The battery boxes must be connected (left box on top of right box) in order to charge.**

2. Follow steps 4-8 from the previous procedure.
3. Reinstall the battery boxes onto the scooter.

**NOTE: There is a charger inhibit function on your scooter. The scooter will not run and the battery condition meter will not operate while the batteries are charging.**

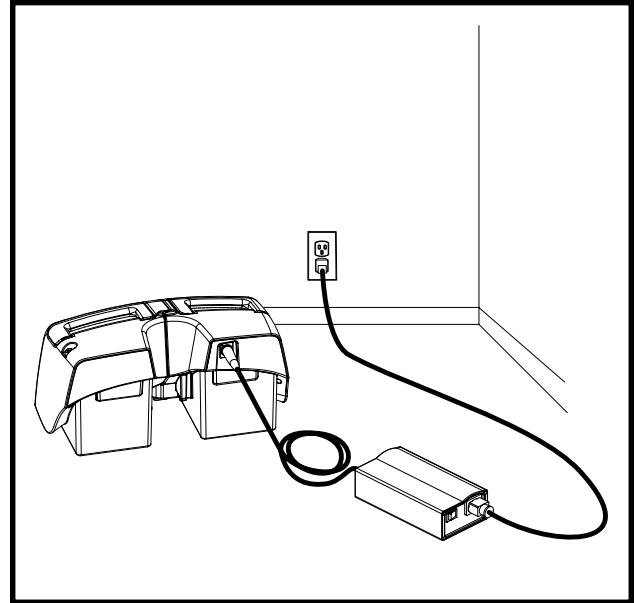

**Figure 10B. Off-board Charging - Battery Boxes Removed From Scooter**

### FREQUENTLY ASKED QUESTIONS

#### **How does the charger work?**

When your scooter’s battery voltage is low, the charger works harder, sending more electrical current to the batteries to bring up their charge. As the batteries approach a full charge, the charger sends less and less electrical current. When the batteries are fully charged, the current sent from the charger is at nearly zero amperage. Therefore, when the charger is plugged in, it maintains the charge on your scooter’s batteries, but does not overcharge them. We do not recommend that you charge your scooter’s batteries for more than 24 consecutive hours.

#### **Can I use a different charger?**

Chargers are selected precisely for particular applications and are especially matched to the type, size and chemical formulation of specific batteries. For the safest and most efficient charging of your scooter’s batteries we recommend only use of the charger supplied as original equipment with your Pride product. Any charging method resulting in batteries being charged individually is especially prohibited.

#### **What if my scooter’s batteries won’t charge?**

- Ensure the red (+) and black (-) battery cables are connected properly to the battery terminals.
- Ensure both battery harnesses that extend from the batteries are plugged into their mating harness leading to the charger.
- Ensure both ends of the charger power lead are inserted fully.

#### **How often must I charge the batteries?**

Two major factors must be considered when deciding how often to charge your scooter’s batteries:

- All day scooter use on a daily basis.
- Infrequent or sporadic scooter use.

## IV. BATTERIES AND CHARGING

With these considerations in mind, you can determine how often and for how long you should charge your scooter's batteries. We designed the off-board charger so that it will not overcharge your scooter's batteries. However, you may encounter some problems if you do not charge your batteries often enough and if you do not charge them on a regular basis.

Following the guidelines below will provide safe and reliable battery operation and charging.

- If you use your scooter daily, charge its batteries as soon as you finish using it for the day. Your scooter will be ready each morning. We recommend that you charge your scooter's batteries for 8 to 14 hours after daily use.
- If you use your scooter once a week or less, charge its batteries at least once a week for 12 to 14 hours at a time.
- Keep your scooter's batteries fully charged.
- Avoid deeply discharging your scooter's batteries.

### How can I ensure maximum battery life?

Fully charged deep-cycle batteries provide reliable performance and extended battery life. Keep your scooter's batteries fully charged whenever possible. Protect your scooter and batteries from extreme heat or cold. Batteries that are regularly and deeply discharged, infrequently charged, stored in extreme temperatures or stored without a full charge may be permanently damaged, causing unreliable performance and limited service life.

### How can I get maximum range or distance per charge?

Rarely will you have ideal driving conditions—smooth, flat, hard driving surfaces with no wind or curves. Often, you will face hills, pavement cracks, uneven and loosely packed surfaces, curves and wind, all of which affect the distance or running time per battery charge. Below are a few suggestions for obtaining the maximum range per battery charge.

- Always fully charge your scooter's batteries prior to daily use.
- Maintain but do not exceed the psi/bar/kPa air pressure rating indicated on each tyre.
- Plan your route ahead to avoid as many hills, cracked, broken or soft surfaces as possible.
- Limit your baggage weight to essential items.
- Try to maintain an even speed while your scooter is in motion.
- Avoid stop-and-go driving.

### What type and size of battery should I use?

We recommend deep-cycle batteries that are sealed and maintenance free. Both AGM and Gel-Cell are deep-cycle batteries that are similar in performance. Do not use wet-cell batteries, which have removable caps.



WARNING! Corrosive chemicals are contained in batteries. Use only AGM or Gel-Cell batteries to reduce the risk of leakage or explosive conditions.

**NOTE: Sealed batteries are not serviceable. Do not remove the caps.**

### How do I change a battery in my scooter?



MANDATORY! Battery posts, terminals and related accessories contain lead and lead compounds. Wear goggles and gloves when handling batteries and wash hands after handling.



WARNING! Always use two batteries of the exact same type, chemistry and amp-hour (Ah) capacity. Refer to the specifications table in this manual and in the manual supplied with the battery charger for recommended type and capacities.

## IV. BATTERIES AND CHARGING

WARNING! Do not mix old and new batteries. Always replace both batteries at the same time.



WARNING! Contact your authorised Pride Dealer if you have any questions regarding the batteries in your scooter.

WARNING! Do not replace the batteries while the scooter is occupied.

WARNING! The batteries on your scooter should only be serviced or replaced by an authorised Pride Dealer or a qualified technician.

### To change the batteries in your scooter:

1. Remove the seat and battery shroud.
2. Disconnect the battery tie-down strap.
3. Disconnect the battery harnesses by pulling them straight up. **See figure 11.**
4. Disconnect the battery cables from the battery terminals by sliding back the terminal boots and unscrewing the nut from the bolt.
5. Remove the old batteries from the battery wells.
6. Place a new battery in each battery well. Face the battery terminals of each battery away from the seat post. **See figure 12.**
7. Connect the red battery cable to the positive (+) battery terminal on each battery.
8. Connect the black battery cable to the negative (-) battery terminal on each battery.
9. Reposition the terminal boots over the battery terminals.
10. Reconnect the battery harnesses.
11. Reconnect the battery tie-down strap.
12. Reinstall the battery shroud and seat.

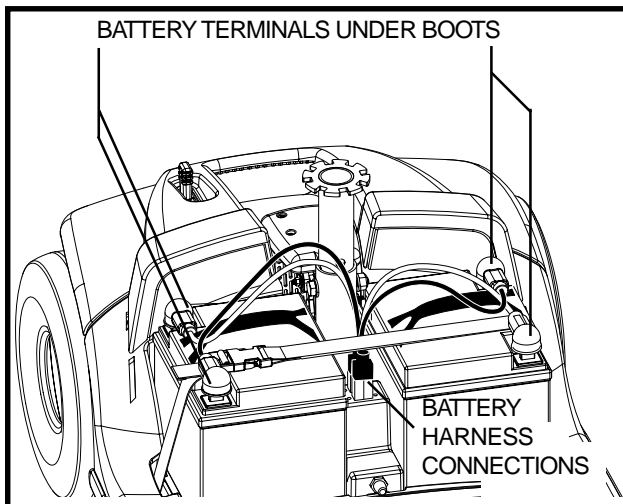

Figure 11. Battery Removal/Installation

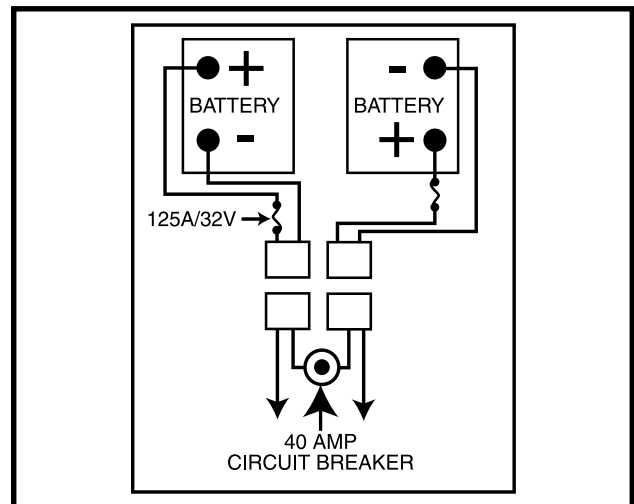

Figure 12. Battery Wiring Diagram

## IV. BATTERIES AND CHARGING

### To change the batteries in a scooter equipped with battery boxes:

1. Remove the seat.
2. Remove the battery boxes from the scooter using the battery box handles. Always remove the left battery box first, then the right battery box.
3. Remove the screws from the underside of the battery boxes.
4. Position the battery boxes with the covers facing up, then carefully remove the covers.
5. Disconnect the battery cables from the battery terminals on each battery by removing the nut and bolt from each battery terminal.

### See figure 13.

6. Remove the old battery from each battery box.
7. Place a new battery in each battery box. Face the battery terminals toward the seat post. See figure 14.
8. Connect the red battery cable to the positive (+) battery terminal on each battery.
9. Connect the black battery cable to the negative (-) battery terminal on each battery.
10. Reinstall the battery box covers.
11. Reinstall the screws to secure the battery box covers.
12. Reinstall the battery boxes to the scooter. Always install the right battery box first, then the left battery box.
13. Reinstall the seat.

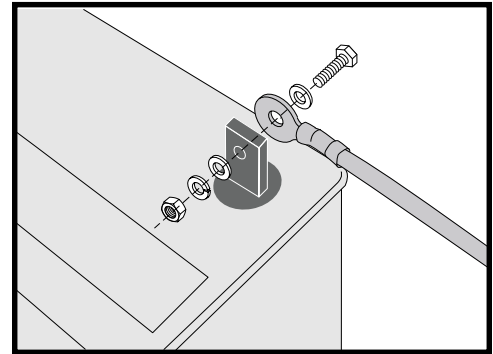

Figure 13. Battery Removal/Installation

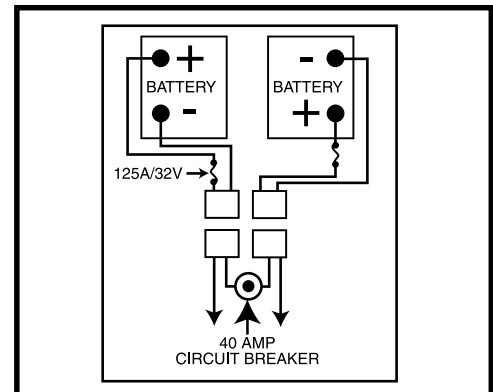

Figure 14. Battery Wiring Diagram

**NOTE:** *If you encounter a damaged or cracked battery, immediately enclose it in a plastic bag. Contact your local waste disposal agency or your authorised Pride Dealer for instructions on disposal and battery recycling, which is our recommended course of action.*

### Why do my new batteries seem weak?

Deep-cycle batteries employ a different chemical technology than that used in car batteries, nickel-cadmium batteries (nicads) and other common battery types. Deep-cycle batteries are specifically designed to provide power, drain down their charge and then accept a relatively quick recharge.

We work closely with our battery manufacturer to provide batteries that best suit your scooter's specific electrical demands. Fresh batteries are shipped fully charged to our customers. During shipping, the batteries may encounter temperature extremes that can influence their initial performance. Heat diminishes the charge on the battery; cold slows the available power and extends the time needed to recharge the battery.

It may take a few days for the temperature of your scooter's batteries to stabilize and adjust to their new room or ambient temperature. More importantly, it takes a few charging cycles (partial draining followed by full recharging) to establish the critical chemical balance that is essential to a deep-cycle battery's peak performance and long life.

## IV. BATTERIES AND CHARGING

Follow these steps to properly break in your scooter's new batteries for maximum efficiency and service life:

1. Fully recharge any new battery prior to its initial use. This charging cycle brings the battery up to about 88% of its peak performance level.
2. Operate your new scooter in familiar and safe areas. Drive slowly at first and do not travel too far from your home or familiar surroundings until you have become accustomed to your scooter's controls and have properly broken in your scooter's batteries.
3. Fully recharge the batteries. They should be at over 90% of their peak performance level.
4. Operate your scooter again.
5. Fully recharge the batteries again.
6. After four or five charging cycles, the batteries are able to receive a charge of 100% of their peak performance level and are able to last for an extended period of time.

### **What about public transportation?**

If you intend to use public transportation with your scooter, you must contact the transportation provider in advance to determine their specific requirements.

# V. OPERATION

## BEFORE GETTING ONTO YOUR SCOOTER

- Have you fully charged the batteries? See IV. “Batteries and Charging.”
- Is the manual freewheel lever in the drive (rearward) position? Never leave the manual freewheel lever pushed forward unless you are manually pushing your scooter.

## GETTING ONTO YOUR SCOOTER

1. Make certain that the key is removed from the key switch.



WARNING! Never attempt to get onto or off of your scooter without first removing the key from the key switch. This will prevent the scooter from moving if accidental throttle control lever contact is made.

2. Stand at the side of your scooter.
3. Disengage the seat rotation lever and rotate the seat until it is facing you.
4. Make certain that the seat is fixed securely in position.
5. Position yourself comfortably and securely in the seat.
6. Disengage the seat rotation lever and rotate the seat until you are facing forward.
7. Make certain that the seat is fixed securely in position.
8. Make certain that your feet are safely on the floorboard.

## PRE-RIDE ADJUSTMENTS AND CHECKS

- Is the seat at the proper height? See VI. “Comfort Adjustments.”
- Is the seat fixed securely in position?
- Is the tiller at a comfortable setting and locked securely in place? See VI. “Comfort Adjustments.”
- Is the key fully inserted into the key switch and turned clockwise to the “on” position?
- Does the horn work properly?
- Is your proposed path clear of people, pets and obstacles?
- Have you planned your route to avoid adverse terrain and as many inclines as possible?

## OPERATING YOUR SCOOTER



WARNING! The following can adversely affect steering and stability while operating your scooter, resulting in loss of control, tipping and/or personal injury:

- Holding onto or attaching a leash to walk your pet
- Carrying passengers (including pets)
- Hanging any article from the tiller
- Towing or being pushed by another motorized vehicle

Keep both hands on the tiller and your feet on the floorboard at all times while operating your scooter. This driving position gives you the most control over your vehicle.

- Set the speed adjustment dial to your desired speed.
- Push or pull the appropriate side of the throttle control lever.
- The electromechanical disc park brake automatically disengages and the scooter accelerates smoothly to the speed you preselected with the speed adjustment dial.
- Pull on the left handgrip to steer your scooter to the left.
- Pull on the right handgrip to steer your scooter to the right.

# V. OPERATION

- Move the tiller to the centre position to drive straight ahead.
- To stop, slowly release the throttle control lever. The electronic brakes will automatically engage, bringing your scooter to a stop.

**NOTE:** *Your scooter's reverse speed is slower than that of the forward speed you preset with the speed adjustment dial.*

## GETTING OFF OF YOUR SCOOTER

1. Bring your scooter to a complete stop.
2. Power down your scooter and remove the key from the key switch.
3. Disengage the seat rotation lever and rotate the seat until you are facing toward the side of your scooter.
4. Make certain that the seat is fixed securely in position.
5. Carefully and safely get out of the seat and stand to the side of your scooter.
6. You can leave the seat facing to the side to facilitate boarding your scooter next time.

## POWER DOWN TIMER FEATURE

Your scooter is equipped with an energy saving automatic power down timer feature designed to preserve your scooter's battery life. If you mistakenly leave the key in the key switch and in the "on" position but do not use your scooter for approximately 20 minutes, the scooter's controller shuts down automatically. Although the controller is shut down, power will still be supplied to the scooter's lighting system.

If the power down timer feature takes effect, perform the following steps to resume normal operation:

1. Remove the key from the key switch.
2. Reinsert the key and power up your scooter.

# VI. COMFORT ADJUSTMENTS

## TILLER ANGLE ADJUSTMENT



**WARNING!** Remove the key from the key switch before adjusting the tiller or the seat. Never attempt to adjust the tiller or the seat while the scooter is in motion.

Your scooter is equipped with an adjustable pivoting tiller.

1. While supporting the tiller, turn the tiller adjustment knob anticlockwise to loosen the tiller. See **figure 15**.
2. Move the tiller to a comfortable position.
3. Turn the tiller adjustment knob clockwise to secure the tiller in position.

**NOTE:** In order to fully lower the tiller for purposes of disassembly or transport, you must first completely remove the seat. See VII. "Disassembly and Assembly."

## MIRROR POSITION

**To install the mirror (see figure 16):**

1. Determine on which side to install the mirror and remove the rubber plug from the top of the tiller handle.
2. Insert the threaded end of the mirror holder into the opening and rotate it clockwise until snug.
3. If necessary, rotate the nut clockwise to secure the mirror in place.

**To adjust the mirror:**

1. Position yourself in a seated driving position facing forward.
2. Adjust the mirror left, right, up or down until you have a good line of sight behind you.

## ARMREST WIDTH ADJUSTMENT

The armrest width can be adjusted inward or outward.

1. Loosen the armrest adjustment knobs. See **figure 17**.
2. Use the attached ring to pull and remove the detent pins.
3. Slide the armrests in or out to the desired width.
4. Align the adjustment holes on the seat frame and armrest, then reinsert the detent pin.
5. Tighten the armrest adjustment knobs.

**NOTE:** Pivot the armrests upward to aid in getting onto and off of your scooter.

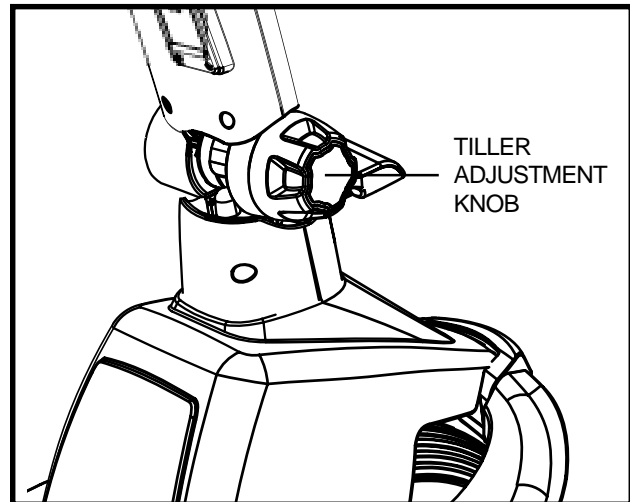

Figure 15. Tiller Adjustment

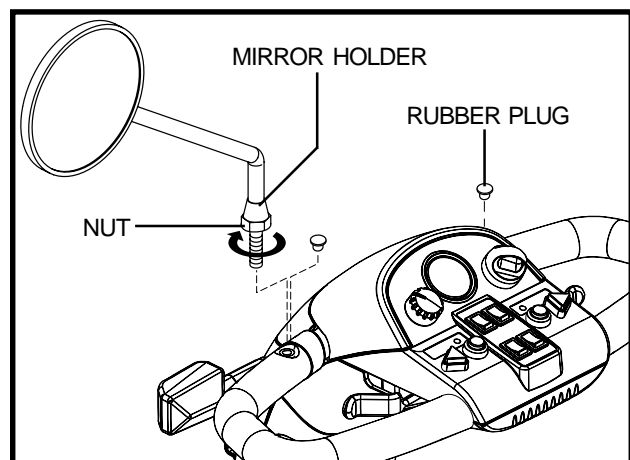

Figure 16. Mirror Installation and Positioning

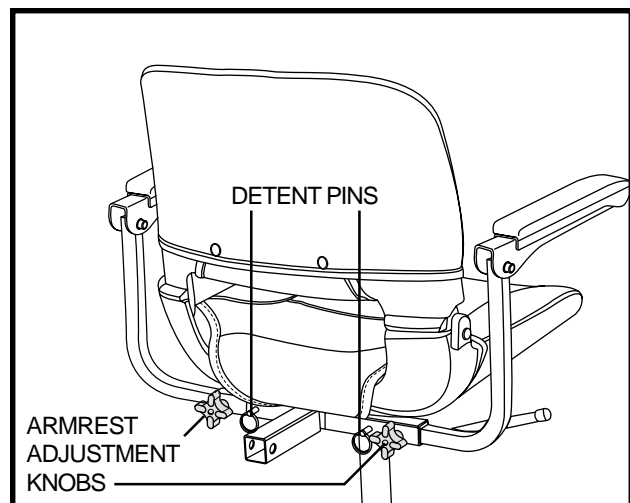

Figure 17. Armrest Width Adjustment

# VI. COMFORT ADJUSTMENTS

## SEAT ROTATION ADJUSTMENT

The seat rotation lever will secure the seat into several positions.

1. Push forward on the seat rotation lever to disengage the seat. **See figure 18.**
2. Rotate the seat to the desired position.
3. Release the lever to secure the seat into place.

## FRONT-TO-BACK SEAT ADJUSTMENT

You can reposition the seat forward or rearward to adjust the distance between the seat and the tiller.

1. Move the seat sliding lever located at the lower left side of the seat outward.
2. While holding the lever out, slide the seat forward or rearward.
3. Release the seat sliding lever once the seat is in the desired position.

## SEAT HEIGHT ADJUSTMENT

The seat can be repositioned to several different heights.

**See figure 19.**

1. Remove the seat and/or shroud from your scooter. See VII. "Disassembly and Assembly."
2. Remove the seat height adjustment bolt.
3. Raise or lower the upper seat post to the desired seat height.
4. While holding the upper seat post at that height, match up the locating holes in the upper seat post with those of the lower seat post.
5. Insert the seat height adjustment bolt through the locating holes of both the upper and lower seat posts.
6. Reinstall the nut onto the seat height adjustment bolt and tighten.
7. Reinstall the rear shroud and the seat.

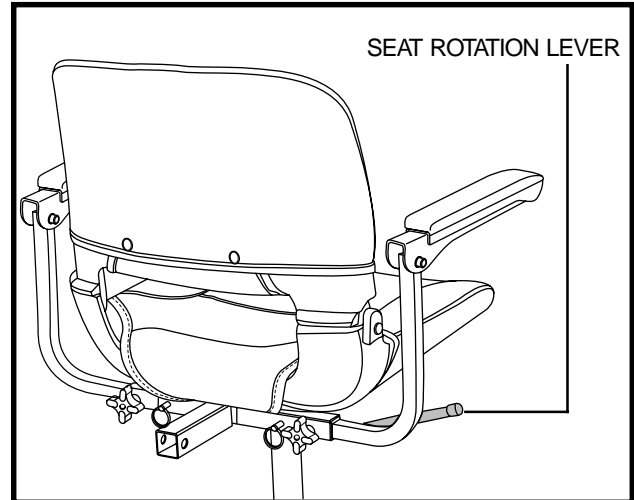

Figure 18. Seat Position Adjustments

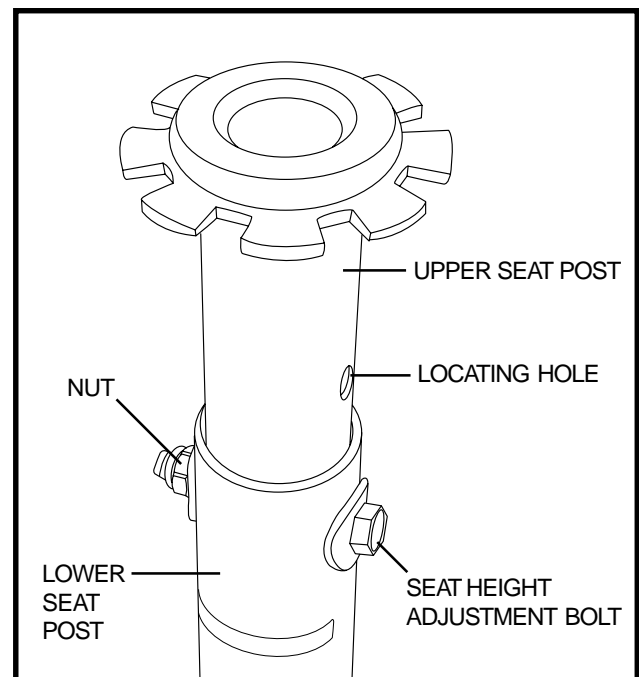

Figure 19. Seat Height Adjustment

# VI. COMFORT ADJUSTMENTS

## POWER SEAT OPTION

Your scooter may be equipped with a power seat. The power seat actuator is designed to raise or lower the seat with minimal effort on the part of the operator. The power seat switch is located on the tiller console.

**WARNING!** The power seat is intended for operation only while your scooter is stationary and on a level surface. Its purpose is to aid you in reaching objects. Drive your scooter only with the power seat in the lowest position. Driving the scooter with the power seat elevated could cause instability in the scooter, resulting in a tip or a fall.



Strict adherence to the following safety rules is vital to your safety:

- Operate the power seat only while completely stationary on level ground.
- Do not press the throttle control lever and the power seat switch at the same time.
- Do not operate your scooter with the power seat elevated. Operate the scooter only with the power seat fully retracted (in the lowest position).
- Never place your scooter in freewheel mode with the power seat elevated.
- Use extreme caution when reaching for objects with your power seat elevated. Do not overextend or attempt to pick up objects that might affect your balance.
- Do not attempt to raise or lower the seat while in motion.

Before operating the power seat, ensure your scooter is level and stationary and the speed adjustment dial is set to the slowest setting.

### To operate the power seat:

1. Press and hold the upper part of the power seat switch to raise the seat. Release the switch when you have attained your desired height or upon reaching the highest position.
2. Press and hold the lower part of the power seat switch to lower the seat. Release the switch when you have attained your desired height or upon reaching the lowest position.

***NOTE: The scooter must be stopped in order for the power seat to be operated. If the power seat switch is pressed while the scooter is in motion, the scooter will slow and come to a stop. The scooter may also produce a fault code. If a fault code occurs, you will need to turn the scooter's power off, then back on again before proceeding.***

# VII. DISASSEMBLY AND ASSEMBLY

## DISASSEMBLY

You can disassemble the scooter into several pieces: the seat, the front section, the rear section, the battery shroud (if equipped), the basket and the batteries or battery boxes. **See figure 20.** No tools are required to disassemble or assemble your scooter, but keep in mind that the disassembled sections of the scooter take up more floor space than the assembled unit. Always disassemble or assemble your scooter on a level, dry surface with sufficient room for you to work and move around your scooter—about 5 feet (1.5 meters) in all directions. Remember that some scooter components are heavy and you may need assistance when lifting them.



**WARNING!** Do not lift beyond your physical capability. Ask for assistance when necessary while disassembling or assembling your scooter.

### If the scooter is not equipped with battery boxes:

1. Remove the seat by lifting it straight up and off of the scooter. If you encounter resistance when removing the seat, disengage the seat rotation lever and swivel the seat back and forth while lifting up on the seat.
2. Gently pull the battery shroud up and off of the scooter.
3. Disconnect the battery tie-down strap.
4. Unplug both battery harnesses by pulling each harness straight up. **See figure 21.**
5. Remove the batteries from the battery wells.



**WARNING!** Failure to unplug both battery harnesses prior to separating the front and rear sections could result in permanent damage to the scooter.

### If the scooter is equipped with battery boxes:

1. Remove the seat by lifting it straight up and off of the scooter. If you encounter resistance when removing the seat, disengage the seat rotation lever and swivel the seat back and forth while lifting up on the seat.
2. Remove the left battery box, then the right battery box.

**NOTE:** Always remove the left battery box first.

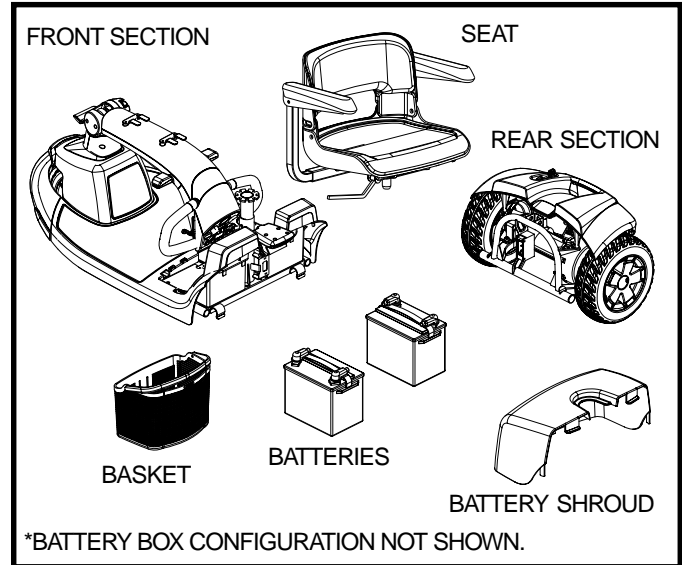

**Figure 20. Scooter Components**

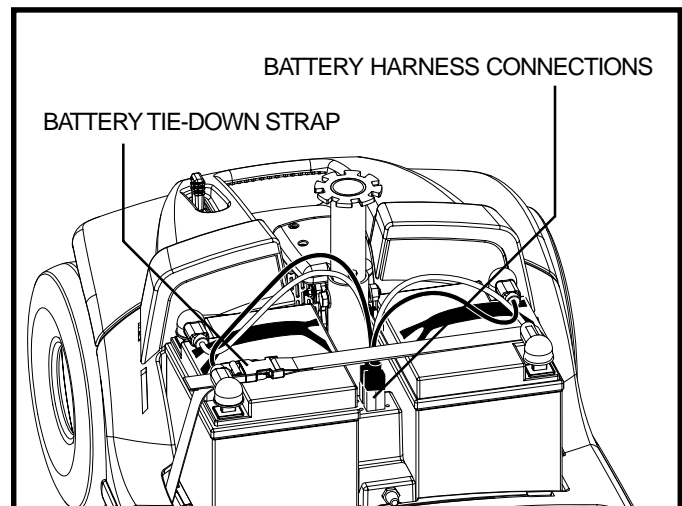

**Figure 21. Harness Connections**

# VII. DISASSEMBLY AND ASSEMBLY

## Frame Separation

1. Arrange the front wheel(s) in a straight forward-facing position.
2. Lower the tiller and tighten the tiller adjustment knob.

**NOTE:** *The pivoting tiller is equipped with a mechanism that will lock the front wheels in place when the tiller is completely lowered and secured.*

3. Grasp and lift up on the frame release lever. See **figure 22**.
4. Lift the front section up until the frame hooks of the front section separate from the rear section. See **figure 23**.
5. Slowly separate the two sections. See **figure 23**.

## ASSEMBLY

1. Position the front and rear sections of your scooter as shown in **figure 23**.
2. Use the frame release lever to lift the front section as you align the frame hooks of the front section with the lower frame tube of the rear section. See **figure 23**.
3. Once the frame hooks are over the lower frame tube, lower the front section completely. This will engage the frame lock.
4. Raise the tiller and fully tighten the tiller adjustment knob.

### If the scooter is not equipped with battery boxes:

1. Reinstall the batteries to the battery wells.
2. Connect both battery harnesses. See **figure 21**.
3. Secure the battery tie-down strap.
4. Reinstall the battery shroud.
5. Reinstall the seat and rotate it into place.

### If the scooter is equipped with battery boxes:

1. Reinstall the right battery box, then the left battery box.

**NOTE:** *Always install the right battery box first.*

2. Reinstall the seat and rotate it into place.

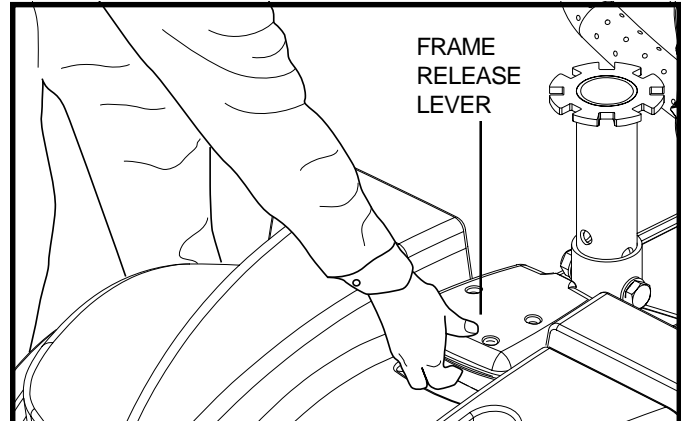

Figure 22. Frame Release Lever

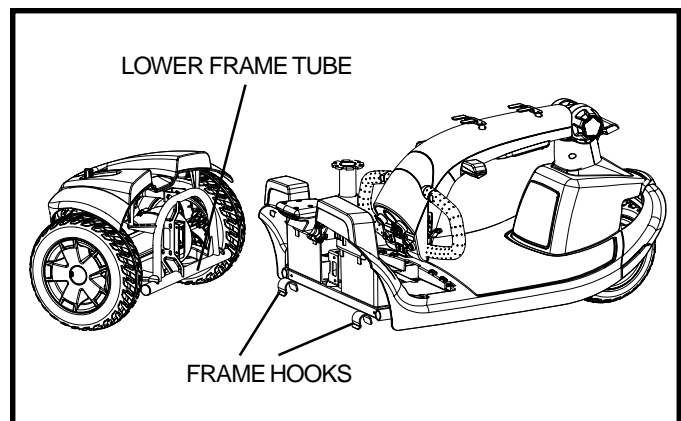

Figure 23. Frame Separation

## VIII. BASIC TROUBLESHOOTING

Any electromechanical device occasionally requires some troubleshooting. However, most of the problems that may arise can usually be solved with a bit of thought and common sense. Many of these problems occur because the batteries are not fully charged or because the batteries are worn down and can no longer hold a charge.

### DIAGNOSTIC FAULT CODES

The diagnostic fault codes for your scooter are designed to help you perform basic troubleshooting quickly and easily. A diagnostic flash code will flash from the status LED in the event one of the conditions listed below develops. Your scooter will also emit a beep code to indicate the system fault.

**NOTE:** *Your scooter will not run unless the fault code condition is resolved and the scooter has been turned off, then turned back on.*

FAULT CODE	CONDITION	SOLUTION
■ (1)	Battery charge is low.	Charge batteries as soon as possible.
■ ■ (2)	Battery charge is too low to operate the scooter.	Charge batteries.
■ ■ ■ (3)	The scooter's battery voltage is too high to operate the scooter, or the charger is still connected to charger port.	Unplug charger and/or turn key off, then back on again.
■ ■ ■ ■ (4)	Current limit time out.	Turn the scooter off for a few minutes, then turn your scooter back on.
■ ■ ■ ■ ■ (5)	The manual freewheel lever is in the (forward) freewheel position.	Remove the key from the key switch, then push the manual freewheel lever to the (rear) drive position, and restart your scooter.
■ ■ ■ ■ ■ ■ (6)	Throttle control lever not at centre position at start up.	Return the throttle control lever to centre position, turn scooter off, and then back on.
■ ■ ■ ■ ■ ■ ■ (7)	Speed pot error.	Contact your authorised Pride Dealer for assistance.
■ ■ ■ ■ ■ ■ ■ ■ (8)	Motor volts error.	Contact your authorised Pride Dealer for assistance.
■ ■ ■ ■ ■ ■ ■ ■ ■ (9)	Other internal errors.	Contact your authorised Pride Dealer for assistance.

#### What if all the systems on my scooter seem to be dead?

- Make certain that the key is in the “on” position.
- Check that the batteries are fully charged.
- Push in the main circuit breaker reset button. See III. “Your Scooter.”
- Make certain that both battery harnesses and the front-to-rear harness are firmly connected. See VII. “Disassembly and Assembly.”
- Be sure the power down timer feature has not been activated. See V. “Operation.”

#### What if my scooter does not move when I engage the throttle control lever?

- When the manual freewheel lever is pushed forward, the brakes are disengaged and all power to the motor/transaxle assembly is cut.
- Push rearward on the manual freewheel lever, turn the scooter off and then turn the scooter on to return to normal scooter operation.

## VIII. BASIC TROUBLESHOOTING

### **What if the main circuit breaker repeatedly trips?**

- If the main circuit breaker trips repeatedly, see your authorised Pride Dealer for service.
- Charge the batteries more frequently. See IV. “Batteries and Charging.”
- If the problem continues, have both of your scooter’s batteries load tested by your authorised Pride Dealer.
- You may also perform the load test yourself. Battery load testers are available at most automotive parts stores. Follow the directions supplied with the load tester.
- See IV. “Batteries and Charging” or “Appendix I - Specifications” for information about your scooter’s battery type.

### **What if the battery condition meter dips way down and the motor surges or hesitates when I engage the throttle control lever?**

- Fully charge your scooter’s batteries. See IV. “Batteries and Charging.”
- Have your authorised Pride Dealer load test each battery.
- See the previous troubleshooting question for load testing the batteries yourself.

If you experience any problems with your scooter that you are not able to solve, immediately contact your authorised Pride Dealer for information, maintenance and service.

# IX. CARE AND MAINTENANCE

Your scooter requires a minimal amount of care and maintenance. If you do not feel confident in your ability to perform the maintenance listed below, you may schedule inspection and maintenance at your authorised Pride Dealer. The following areas require periodic inspection and/or care and maintenance.

## TYRE PRESSURE

- If equipped with pneumatic tyres, always maintain the psi/bar/kPa air pressure rating indicated on each tyre.



WARNING! It is important that the psi/bar/kPa air pressure rating indicated on each tyre be maintained in pneumatic tyres at all times. Do not underinflate or overinflate your tyres. Low pressure may result in loss of control and overinflated tyres may burst. Failure to maintain the psi/bar/kPa air pressure rating indicated on the tyres at all times may result in tyre and/or wheel failure.

- Regularly inspect your scooter's tyres for signs of wear.

## WHEEL REPLACEMENT

If your scooter is equipped with pneumatic tyres and you have a flat tyre, you can have the tube replaced. If your scooter is equipped with a solid tyre insert, either the solid insert or the entire wheel must be replaced depending on the model. Contact your authorised Pride Dealer for information regarding replacement wheels for your scooter.

WARNING! Wheels on your scooter should only be serviced/replaced by an authorised Pride Dealer or qualified technician.



WARNING! Completely deflate pneumatic tyres before dismantling the rim or attempting repair.

WARNING! When changing a tyre, remove only the centre lug nut, then remove the wheel. If any further disassembly is required, deflate the tyre completely or it may explode.

## EXTERIOR SURFACES

Bumpers, tyres and trim can benefit from an occasional application of a rubber or vinyl conditioner.



WARNING! Do not use a rubber or vinyl conditioner on the scooter's vinyl seat or tyre tread, as this may cause them to become dangerously slippery.

## CLEANING AND DISINFECTION

- Use a damp cloth and mild, non-abrasive cleanser to clean the plastic and metal parts of your scooter. Avoid using products that may scratch the surface of your scooter.
- If necessary, clean your product with an approved disinfectant. Make sure the disinfectant is safe for use on your product before application.



WARNING! Follow all safety instructions for the proper use of the disinfectant and/or cleaning agent before applying it to your product. Failure to comply may result in skin irritation or premature deterioration of upholstery and/or scooter finishes.

## BATTERY TERMINAL CONNECTIONS

- Make certain that the terminal connections remain tight and uncorroded.
- The batteries must sit flat in the battery wells.
- The battery terminals should face towards the inside of the scooter.

# IX. CARE AND MAINTENANCE

## WIRING HARNESSES

- Regularly check all wiring connections.
- Regularly check all wiring insulation, including the charger power lead, for wear or damage.
- Have your authorised Pride Dealer repair or replace any damaged connector, connection or insulation that you find before using your scooter again.



PROHIBITED! Even though the scooter has passed the necessary testing requirements for ingress of liquids, you should keep electrical connections away from sources of dampness, including direct exposure to water or bodily fluids and incontinence. Check electrical components frequently for signs of corrosion and replace as necessary.

## ABS PLASTIC SHROUDS

- The front tiller shroud, front shroud and the rear shroud are formed from durable ABS plastic and are coated with an advanced formula urethane paint.
- A light application of car wax will help the shrouds retain their high gloss.

## AXLE BEARINGS AND THE MOTOR/TRANSAXLE ASSEMBLY

These items are all prelubricated, sealed and require no subsequent lubrication.

## MOTOR BRUSHES

The motor brushes are housed inside of the motor transaxle/assembly. They should be inspected periodically for wear by your authorised Pride Dealer.

## CONSOLE, CHARGER AND REAR ELECTRONICS

- Keep these areas free of moisture.
- Allow these areas to dry thoroughly if they have been exposed to moisture before operating your scooter again.

## FUSE REPLACEMENT

**In the event a fuse should cease to work:**

1. Remove the fuse by pulling it out of its slot.
2. Examine the fuse to be sure it is blown. **See figures 24 and 24A.**
3. Insert a new fuse of the same rating.



WARNING! The replacement fuse must exactly match the rating of the fuse being replaced. Failure to use properly rated fuses may cause damage to the electrical system.

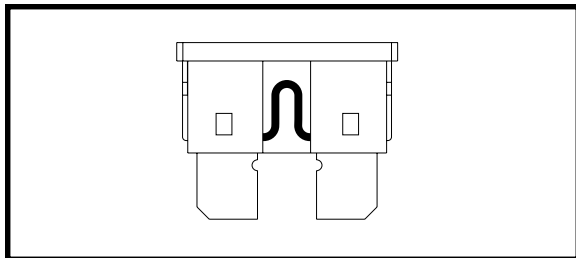

Figure 24. Working Fuse

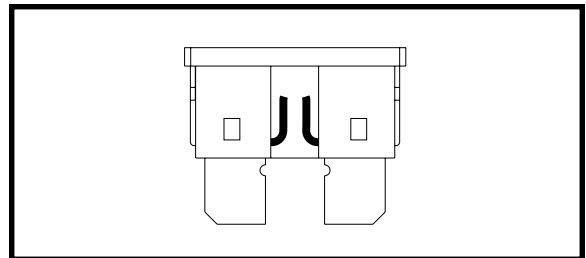

Figure 24A. Blown Fuse (Replace)

# IX. CARE AND MAINTENANCE

## **NYLON LOCK NUT REPLACEMENT**

Any nylon insert lock nut removed during the periodic maintenance, assembly or disassembly of the scooter must be replaced with a new nut. Nylon insert lock nuts should not be reused as it may cause damage to the nylon insert, resulting in a less secure fit. Replacement nylon insert lock nuts are available at local hardware stores or through your authorised Pride Dealer.

## **STORING YOUR SCOOTER**

If you plan on not using your scooter for an extended period of time, it is best to:

1. Fully charge its batteries prior to storage.
2. Disconnect the batteries from the scooter.
3. Store your scooter in a warm, dry environment.
4. Avoid storing your scooter where it will be exposed to temperature extremes.



**WARNING!** Always protect batteries from freezing temperatures and never charge a frozen battery. Charging a frozen battery can result in damage to the battery.

Batteries that are regularly and deeply discharged, infrequently charged, stored in extreme temperatures or stored without a full charge may be permanently damaged, causing unreliable performance and limited service life. It is recommended that you charge the scooter batteries periodically throughout periods of prolonged storage to ensure proper performance.

You may wish to place several boards under the frame of your scooter to raise it off of the ground during periods of prolonged storage. This takes the weight off the tyres and reduces the possibility of flat spots developing on the areas of the tyres contacting the ground.

## **DISPOSAL OF YOUR SCOOTER**

Your scooter must be disposed of according to applicable local and national statutory regulations. Contact your local waste disposal agency or authorised Pride Dealer for information on proper disposal of packaging, metal frame components, plastic components, electronics and batteries.

# X . W A R R A N T Y

## **LIFETIME WARRANTY**

Structural frame components, including: platform, fork, seat post and frame welds.

## **TWO-YEAR LIMITED WARRANTY**

Drivetrain, including: transaxle, motor and brake.

## **ONE-YEAR LIMITED WARRANTY**

All electrical parts, including controllers and battery chargers, are covered for one year under warranty. Any attempt to open or dismantle these parts will lead to this warranty being void.

## **BATTERIES**

Batteries are covered by a twelve-month warranty from the original manufacturer.

## **NOT COVERED UNDER WARRANTY**

The following are classed as wear items, which may, under normal wear and tear, require replacing. These items are not therefore covered under warranty: tyres, lap belts, bulbs, upholstery, plastic shrouds, motor brushes and fuses. Warranty will also be refused if damage is deemed to have been caused through misuse or accident for which Pride Mobility Products Ltd. cannot be deemed responsible.

***NOTE: Pride Mobility Products Ltd. provides parts only under warranty. Your Pride Dealer is responsible for labour and service. Please contact your Pride Dealer for information about these services and for any applicable charges.***

# APPENDIX I - SPECIFICATIONS

Model Number	SC712
Class of Use	B
Maximum Safe Slope	14.1% (8°)
Maximum Climbing Ability	14.1% (8°)
Obstacle Climbing Ability	5 cm (2 in.)
Colours	Red, Blue
Overall Length <sup>4</sup>	116.84 cm (46 in.)
Overall Width <sup>4</sup>	56.5 cm (22.25 in.)
Total Weight Without Batteries	68.27 kg (150.5 lbs.)
Heaviest Piece When Disassembled	24.95 kg (55 lbs.)
Turning Radius <sup>4</sup>	47 in. (106.7 cm)
Speed (Maximum) <sup>1</sup>	8.45 km/h (5.25 mph)
Range Per Charge (Theoretical value based on Test Standards) <sup>1,2</sup>	Up to 17.85 km (11.09 miles)
Range Per Charge (Value based on Straight-line Test Simulation) <sup>1,3</sup>	Up to 40 km (25 miles)
Ground Clearance <sup>4</sup>	5.7 cm (2.25 in.)
Weight Capacity	158.75 kg , 25 stone (350 lbs.)
Standard Seating	Type: Foldable Moulded Plastic Weight: 12.7 kg (28 lbs.) Material: Black Vinyl Dimensions: 45.72 cm (18 in.) width; 40.64 cm (16 in.) depth
Tyres	25.4 cm (10 in.) solid tires
Drive System	Rear-wheel drive, sealed transaxle, 24-volt DC motor
Dual Braking System	Electronic, regenerative and electromechanical
Battery Requirements <sup>5</sup>	Two 12-volt, deep-cycle Size: U1 (31–36 Ah) or optional 40 Ah U1 Battery Weight: 10.43 kg (23 lbs.) each 40 Ah Battery Weight: 14.74 kg (32.5 lbs.) each
Battery Charger	3-amp, off-board with U1 batteries 5-amp, off-board with 40 Ah batteries

<sup>1</sup> Varies with user weight, terrain type, battery amp-hour (Ah), battery charge, battery condition and tyre condition. This specification can be subject to a variance of (+ or -) 10%.

<sup>2</sup> Tested in accordance with ASNI/RESNA, WC Vol 2, Section 4 & ISO 7176-4 standards. Results derived from theoretical calculation based on battery specifications and drive system performance. Test conducted at maximum weight capacity.

<sup>3</sup> Tested by Pride Mobility Products under simulated conditions; continuous straight-line driving until total battery depletion. Test conducted at maximum weight capacity.

<sup>4</sup> Due to manufacturing tolerances and continual product improvement, this specification can be subject to a variance of (+ or -) 3%.

<sup>5</sup> AGM or Gel-Cell type required. See IV. "Batteries and Charging."

*NOTE: This product conforms to all applicable ANSI-RESNA testing requirements and ISO 7176 series EN12184 standards. All specifications subject to change without notice.*

# APPENDIX I - SPECIFICATIONS

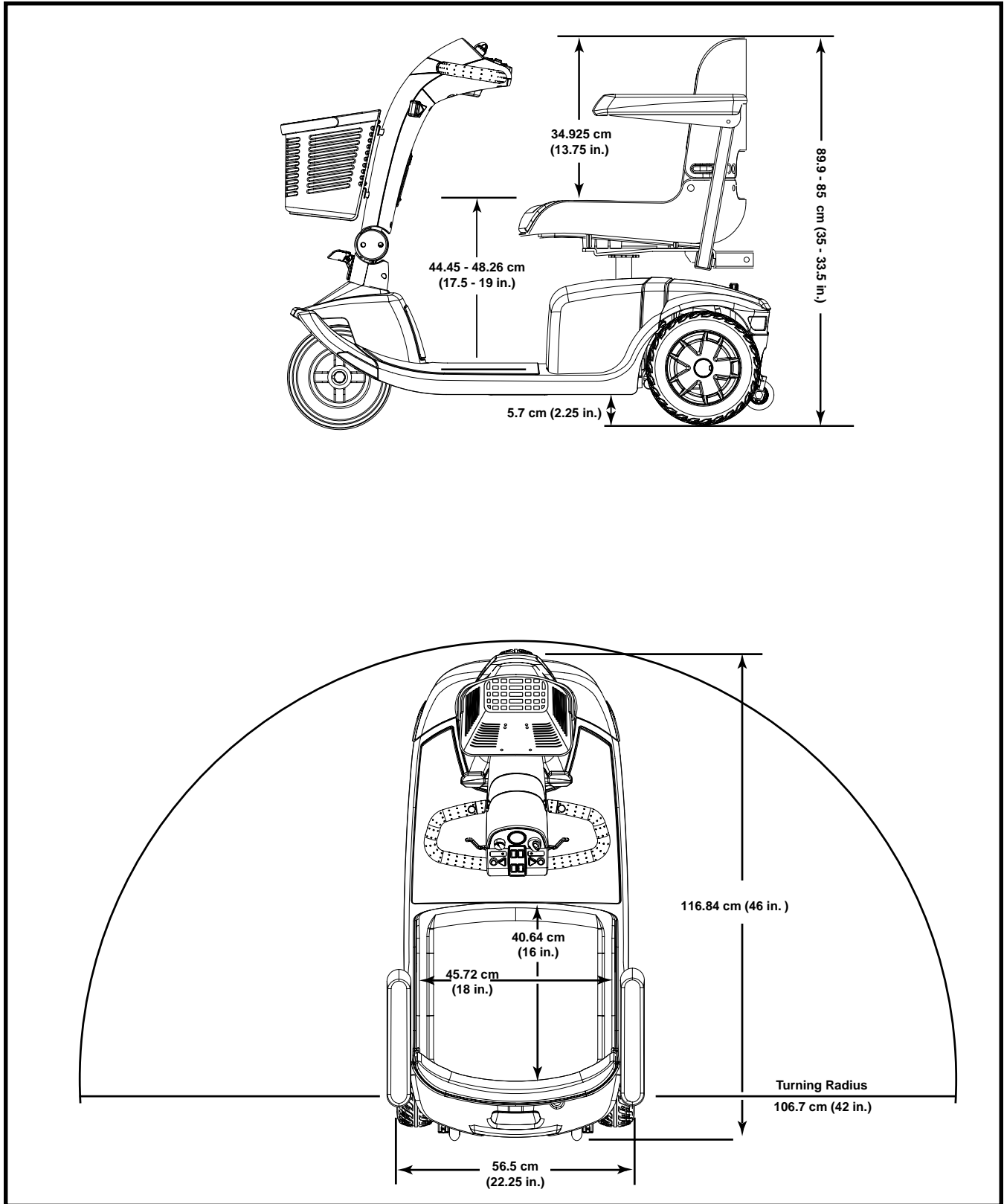

Figure 25. Scooter Dimensions

# NOTES





***Pride***  
*Mobility Products Ltd.*

*32 Wedgwood Road  
Bicester, Oxon OX26 4UL*

*[www.pridemobility.com](http://www.pridemobility.com)*